

HEIKO



Ensure comfort
wherever
you stay

CATALOGUE
Air Conditioning Systems
Heat Pumps

heiko.pl

HEIKO



Heiko offers air
conditioning systems
and heat pumps



BRAND

Heiko is a brand that was created in response to the needs of the growing market. Its dynamic enables the introduction of cutting-edge technologies. Heiko systems are friendly solutions for the Users, the Installers and the environment. Our brand is distinguished by a wide range of appliances for homes, offices and business.

COMFORT

Heiko prioritizes User comfort. The appliances are characterized by: quiet operation, high energy efficiency, intelligent Wi-Fi control and easy and quick installation. Split and Multi Split air conditioners ensure efficient operation in independent modes: cooling, heating, drying, fan and AUTO. THERMAL and THERMAL Plus heat pumps feature energy-saving and quiet operation in a wide range of temperatures.

EFFICIENCY

Air conditioning systems and heat pumps operate based on the eco-friendly R32 refrigerant, which is characterized by reduced global warming potential. In addition, Heiko is distinguished by the inverter technology that significantly reduces the electricity consumption.

SPLIT Air Conditioners



High energy efficiency

HEIKO air conditioning systems are energy-saving devices that, in addition to the basic cooling function, also have the option of heating the room. They are great for home and commercial facilities.

Device operation

The operation of the device is simple and intuitive. Most wall units come with a Wi-Fi module as standard. Control is facilitated by a wireless remote control or a wired controller. A dedicated application for mobile devices allows remote control of the device.

Design

HEIKO air conditioners will perfectly fit into any interior. Their timeless design will make them stand out additional element of room decor.

User comfort





















Out of concern for the comfort of use, the air conditioners are equipped with components that guarantee quiet operation of the device. This allows for a peaceful rest without unnecessary and burdensome noise.



SPLIT air conditioning systems consist of two basic elements - the indoor unit, which is installed inside the room, and the aggregate mounted outside.

SPLIT

Models available

Indoor and outdoor units	Refrigerant	Controller	
BRISA wall-mounted air conditioner			YR-HAC01 wireless controller (included)
NEW			
QIRA wall-mounted air conditioner			YR-HAC01 wireless controller (included)
ARIA wall-mounted air			YR-HAC01 wireless controller (included)
C1 wall-mounted air conditioners			YR-HAC01 wireless controller (included)
CASSETTE air conditioners with 4- way airflow		 	 
CASSETTE air conditioners with peripheral airflow		 	 
Mobile air conditioner			Wireless controller (included)

2,5 kW

3,5 kW

5,0 kW

7,0 kW

10,0 kW



JS025-C2



JZ025-C2



JS035-C2



JZ035-C2



JS050-C2



JZ050-C2



JS070-C2



JZ070-C1

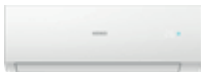

JS025-QW2



JZ025-Q2

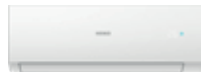

JS035-QW2



JZ035-Q2

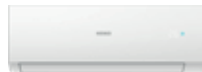

JS050-QW2



JZ050-Q2



JS025-A1



JZ025-A1



JS035-A1



JZ035-A1



JS035-C1



JZ035-C1



CA035-A1



JZ035-A1/JZ035-A2



CA050-A1



JZ050-A1/JZ050-A2



CA070-A1

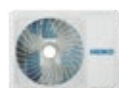

JZ070-A1



CA100-A1



JZ100-A1



AM12HEIA4

SPLIT

BRISA wall-mounted air conditioners

BRISA wall-mounted air conditioners are advanced appliances with high energy efficiency, equipped with top quality compressors. The sophisticated style of BRISA air conditioners makes them a perfect choice for homes and offices. The temperature control and the use of air conditioner functionalities are facilitated by the Wi-Fi control in standard and the included wireless controller.

TEMPERATURE SETPOINT from 16 to 30°C



Wi-Fi control

The Wi-Fi control in standard enables controlling the air conditioner with your smartphone connected to the Internet from any place. The comfortable and intuitive Wi-Fi INTELLIGENT AIR app enables access to all basic settings of the air conditioner.



High energy efficiency

Innovative solutions enabled a significant reduction of energy consumption in both cooling and heating mode. The appliances have A++/A+ energy rating.



SMART airflow

An innovative solution for airflow control. The stream is directed upwards during the cooling and downwards during the heating, which enables an even distribution of air, thus preventing direct airflow on the user.



Airflow speed control

The option to control airflow shutters vertically and horizontally enables precise direction of the airflow. The up-down control function is available from the wireless controller and the Wi-Fi Intelligent Air app. The left-right control is done manually.



Quiet operation

The components comprising the air conditioner and the optimum airflow system ensure quiet operation for comfort during work and leisure.





Indoor unit



Wireless controller
YR-HAC01 (included)

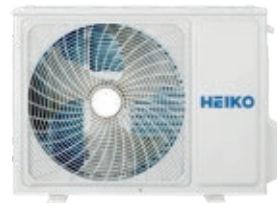

Outdoor unit

Indoor unit			JS025-C2	JS035-C2	JS050-C2	JS070-C2
Outdoor unit			JZ025-C2	JZ035-C2	JZ050-C2	JZ070-C1
Capacity (cooling)	Rated (min – max)	Btu/h	8870 (2730-10238)	10920 (2730-12286)	17060 (4430-19790)	23880 (7500-29000)
	Rated (min – max)	kW	2.6(0.8-3.0)	3.2(0.8-3.6)	5.0(1.3-5.8)	7.0(2.2-8.5)
Energy efficiency	SEER/EER		6.1/3.23	6.1/3.01	6.1/3.41	7.1/3.23
Energy rating	Cooling		A++	A++	A++	A++
Power input (cooling)	Rated (min – max)	kW	0.80(0.30-1.20)	1.06(0.30-1.60)	1.46(0.40-2.00)	2.16(0.70-2.90)
Annual energy consumption (cooling)		kWh	149	184	287	350
Capacity (heating)	Rated (min – max)	Btu/h	9555(2730-10920)	11603(2730-14330)	17740(4770-20470)	27640(8190-34120)
	Rated (min – max)	kW	2.8(0.8-3.2)	3.4(0.8-4.2)	5.2(1.4-6.0)	8.1(2.4-10.0)
Energy efficiency	SCOP/COP (moderate climate)		4.0/3.71	4.0/3.40	4.0/3.71	4.0/3.71
	SCOP (warm/cold climate)		5.1/-	5.1/-	5.1/-	5.1/-
Energy rating (heating)	Moderate/warm/cold climate		A+/A+++/-	A+/A+++/-	A+/A+++/-	A+/A+++/-
Power input (heating)	Rated (min – max)	kW	0.75(0.30-1.40)	1.0(0.30-1.60)	1.40(0.52-2.5)	2.18(0.70-2.90)
Annual energy consumption (heating)		kWh	840	980	1610	1963
Operating range (cooling)	Min – Max (out)	°C	-10 ~ 43	-10 ~ 43	-10 ~ 43	-10 ~ 43
Operating range (heating)	Min – Max (out)	°C	-15 ~ 24	-15 ~ 24	-15 ~ 24	-15 ~ 24
Power supply		f/V/Hz	1/220-240/50	1/220-240/50	1/220-240/50	1/230/50
Power supply (position)			Outdoor unit			
Indoor unit			JS025-C2	JS035-C2	JS050-C2	JS070-C2
Package dimensions	width/depth/height	mm	820/195/280	820/195/280	1008/225/318	1125/240/335
Dimensions with packaging	width/depth/height	mm	909/279/355	909/279/355	1085/329/403	1206/342/418
Net/gross weight		kg	8.2/10.5	8.2/10.5	11.6/14.4	14/17.5
Airflow (cooling/heating)	Max	m ³ /h	500	550	900	1200
Sound power level		dB(A)	54	56	57	60
Sound pressure level		dB(A)	37/33/29/19	38/34/29/20	44/40/35/28	47/43/37/30
Moisture removal capacity		10 ⁻³ m ³ /h	1	1.4	2.0	2.8
Outdoor unit			JZ025-C2	JZ035-C2	JZ050-C2	JZ070-C1
Compressor			HIGHLY	HIGHLY	HIGHLY	HIGHLY
Net dimensions	width/depth/height	mm	700/245/544	700/245/544	800/275/553	890/353/697
Packaging dimensions	width/depth/height	mm	845/320/593	845/320/593	954/409/625	1046/460/780
Net/gross weight		kg	22.8/25.3	23.5/26	32.7/36.5	47.3/52.3
Airflow (cooling/heating)	Max	m ³ /h	2100	2100	2500	2900
Sound power level		dB(A)	62	63	65	65
Sound pressure level		dB(A)	49	50	53	52
Operating current	Max	A	6,2	7,1	11,3	13
Refrigerant filling	Refrigerant type		R32	R32	R32	R32
	Refrigerant filling	g	510	530	900	1200
Refrigerant piping	Liquid pipe diameter	mm	6,35	6,35	6,35	6,35
	Gas pipe diameter	mm	9,52	9,52	12,7	12,7
	Max pipeline length/Max level difference	m	20/10	20/10	25/15	25/15
	Max pipeline length without additional filling	m	5	5	7	7
	Extra refrigerant per metre of pipeline	g/m	20	20	20	20

SPLIT

NEW

QIRA wall-mounted air Conditioners

QIRA air conditioners are a novelty in the offer. The devices are equipped with an improving ionizer the quality of the air supplied by the indoor unit. With this feature, we can reduce the risk of allergies, infections and neutralize odors in the room. In addition, air conditioners are equipped with a Wi-Fi module and a wireless remote control, thanks to which you can control the operation of the device in a given room.

TEMPERATURE SETPOINT from 16 to 30°C

Ionizer



The ionizer improves air quality in the room. Electrical equipment generates positive ions, also referred to as electro smog, that attract dust and viruses. Negative ions are generated by the ionizer neutralize the charge of positive ions by causing the contaminants to fall on the floor, while reducing the risk of allergy and various infections. The ionizer also helps neutralizing the odors in the room.

Wi-Fi control



The Wi-Fi control in standard enables controlling the air conditioner with your smartphone connected to the Internet from any place. The comfortable and intuitive Wi-Fi INTELLIGENT AIR app enables access to all basic settings of the air conditioner.

High energy efficiency



Innovative solutions enabled a significant reduction of energy consumption in both cooling and heating mode. The appliances have A++/A+ energy rating.

SMART airflow



An innovative solution for airflow control. The stream is directed upwards during the cooling and downwards during the heating, which enables an even distribution of air, thus preventing direct airflow on the user.

Airflow speed control



The option to control airflow shutters vertically and horizontally enables precise direction of the airflow. The up-down and left-right control functions are available from the wireless controller and the Wi-Fi Intelligent Air app.

TURBO MODE

ONE-TOUCH
FULL POWER

SLEEP FUNCTION

MAKE YOUR
SLEEP
COMFORTABLE

AUTO COOLING HEATING DRYING FAN



Indoor unit



Wireless controller
YR-HAC01 (included)



Outdoor unit

Indoor unit			JS025-QW2	JS035-QW2	JS050-QW2
Outdoor unit			JZ025-Q2	JZ035-Q2	JZ050-Q2
Capacity (cooling)	Rated (min - max)	Btu/h	8870 (2730-10238)	11940 (2730-12286)	17060 (4430-19790)
	Rated (min - max)	kW	2.6 (0.8-3.0)	3.5 (0.8-3.6)	5.0 (1.3-5.8)
Energy efficiency	SEER/EER		6.1/3.23	6.1/2.9	6.1/3.23
Energy rating	Cooling		A++	A++	A++
Power input (cooling)	Rated (min - max)	kW	0.8 (0.3-1.2)	1.2 (0.3-1.6)	1.55 (0.4-2.0)
Annual energy consumption (cooling)		kWh	149	201	287
Capacity (heating)	Rated (min - max)	Btu/h	9555 (2730-10920)	11940 (2730-14330)	17740 (4770-20470)
	Rated (min - max)	kW	2.8 (0.8-3.2)	3.5 (0.8-4.2)	5.2 (1.4-6.0)
Energy efficiency	SCOP/COP (moderate climate)		4.0/3.71	4.0/3.71	4.0/3.71
	SCOP (warm/cold climate)		5.1/-	5.1/-	5.1/-
Energy rating (heating)	Moderate/warm/cold climate		A+/A+++/-	A+/A+++/-	A+/A+++/-
Power input (heating)	Rated (min - max)	kW	0.75 (0.3-1.4)	0.94 (0.3-1.6)	1.4 (0.52-2.5)
Annual energy consumption (heating)		kWh	840	980	1610
Operating range (cooling)	Min - Max (out)	°C	-10-43	-10-43	-10-43
Operating range (heating)	Min - Max (out)	°C	-15-24	-15-24	-15-24
Power supply		f/V/Hz	1/220-240/50	1/220-240/50	1/220-240/50
Power supply (position)				Outdoor unit	
Indoor unit			JS025-QW2	JS035-QW2	JS050-QW2
Package dimensions	width/depth/height	mm	805/200/290	805/200/290	975/220/320
Dimensions with packaging	width/depth/height	mm	874/270/363	874/270/363	1050/301/397
Net/gross weight		kg	8.3/10.5	8.3/10.5	11.6/14.4
Performance (cooling/heating)	Max	m ³ /h	550	600	900
Sound power level		dB(A)	54	56	57
Sound pressure level		dB(A)	37/32/28/18	37/33/29/19	44/40/35/28
Moisture removal capacity		10 ⁻³ m ³ /h	1	1.3	2
Outdoor unit			JZ025-Q2	JZ035-Q2	JZ050-Q2
Compressor			HIGHLY	HIGHLY	HIGHLY
Net dimensions	width/depth/height	mm	700/245/544	700/245/544	800/275/553
Packaging dimensions	width/depth/height	mm	819/320/585	819/320/589	902/375/607
Net/gross weight		kg	22.8/25.3	23.6/26.1	32.7/36.5
Performance (cooling/heating)	Max	m ³ /h	2100	2100	2500
Sound power level		dB(A)	62	63	65
Sound pressure level		dB(A)	49	50	53
Operating current	Max	A	6,2	7,1	11,3
Refrigerant filling	Refrigerant type		R32	R32	R32
	Refrigerant filling	g	520	530	900
Refrigerant piping	Liquid pipe diameter	mm	6,35	6,35	6,35
	Gas pipe diameter	mm	9,52	9,52	12,7
	Max pipeline length/Max level difference	m	20/10	20/10	25/15
	Max pipeline length without additional filling	m	5	5	7
	Extra refrigerant per metre of pipeline	g/m	20	20	20

SPLIT

ARIA wall-mounted air conditioners

ARIA wall-mounted air conditioners are a perfect solution for allergy sufferers! Appliances are equipped with air ionizers that always generate negative ions during the cooling or heating. Negative ions are generated by the ionizer neutralize the charge of positive ions by causing the contaminants to fall on the floor, while reducing the risk of allergy and various infections. The ionizer also helps neutralizing the odors in the room.

TEMPERATURE SETPOINT from 16 to 30°C



Ionizer

The ionizer improves air quality in the room. Electrical equipment generates positive ions, also referred to as electro smog, that attract dust and viruses. Negative ions are generated by the ionizer neutralize the charge of positive ions by causing the contaminants to fall on the floor, while reducing the risk of allergy and various infections. The ionizer also helps neutralizing the odors in the room.



Wi-Fi control

The Wi-Fi control in standard enables controlling the air conditioner with your smartphone connected to the Internet from any place. The comfortable and intuitive Wi-Fi INTELLIGENT AIR app enables access to all basic settings of the air conditioner.



High energy efficiency

Innovative solutions enabled a significant reduction of energy consumption in both cooling and heating mode. The appliances have A+++/A+ energy rating.



SMART airflow

An innovative solution for airflow control. The stream is directed upwards during the cooling and downwards during the heating, which enables an even distribution of air, thus preventing direct airflow on the user.



Airflow speed control

The option to control airflow shutters vertically and horizontally enables precise direction of the airflow. The up-down and left-right control functions are available from the wireless controller and the Wi-Fi Intelligent Air app





Indoor unit



Wireless controller
YR-HAC01 (included)



Outdoor unit

Indoor unit			JS025-A1	JS035-A1
Outdoor unit			JZ025-A1	JZ035-A1
Capacity (cooling)	Rated (min - max)	Btu/h	8870 (2730-10920)	11940 (3410-13650)
	Rated (min - max)	kW	2.6(0.8-3.2)	3.5(1.0-4.0)
Energy efficiency	SEER/EER		8.5/4.00	8.5/4.00
Energy rating	Cooling		A+++	A+++
Power input (cooling))	Rated (min - max)	kW	0.65(0.2-1.5)	0.88(0.3-1.5)
Annual energy consumption (cooling)		kWh	107	144
Capacity (heating)	Rated (min - max)	Btu/h	10920(2730-14330)	14330(3410-17740)
	Rated (min - max)	kW	3.2(0.8-4.2)	4.2(1.0-5.2)
Energy efficiency	SCOP/COP (moderate climate)		4.6/4.0	4.6/3.81
	SCOP (warm/cold climate)		5.5/-	5.5/-
Energy rating (heating)	Moderate/warm/cold climate		A++/A+++/-	A++/A+++/-
Power input (heating)	Rated (min - max)	kW	0.8(0.30-1.60)	1.1(0.50-1.60)
Annual energy consumption (heating)		kWh	731	854
Operating range (cooling)	Min - Max (out)	°C	-20 ~ 43	-20 ~ 43
Operating range (heating)	Min - Max (out)	°C	-20 ~ 24	-20 ~ 24
Power supply		f/V/Hz	1/230/50	1/230/50
Power supply (position)			Outdoor unit	
Indoor unit			JS025-A1	JS035-A1
Package dimensions	width/depth/height	mm	870/196/301	870/196/301
Dimensions with packaging	width/depth/height	mm	952/283/389	952/283/389
Net/gross weight		kg	9.5/12	9.5/12
Performance (cooling/heating)	Max	m ³ /h	600	650
Sound power level		dB(A)	53	55
Sound pressure level		dB(A)	38/32/25/19	39/33/26/20
Moisture removal capacity		10 ⁻³ m ³ /h	1.2	1.6
Outdoor unit			JZ025-A1	JZ035-A1
Compressor			PANASONIC	HIGHLY
Net dimensions	width/depth/height	mm	800/275/553	800/275/553
Packaging dimensions	width/depth/height	mm	954/409/625	954/409/625
Net/gross weight		kg	29/31.5	31.5/34
Performance (cooling/heating)	Max	m ³ /h	1900	2000
Sound power level		dB(A)	59	61
Sound pressure level		dB(A)	47	48
Operating current	Max	A	7,2	7,2
Refrigerant filling	Refrigerant type		R32	R32
	Refrigerant filling	g	650	940
Refrigerant piping	Liquid pipe diameter	mm	6,35	6,35
	Gas pipe diameter	mm	9,52	9,52
	Max pipeline length/Max level difference	m	20/10	20/10
	Max pipeline length without additional filling	m	7	7
	Extra refrigerant per metre of pipeline	g/m	20	20

SPLIT

C1 wall-mounted air conditioners

C1 wall-mounted air conditioners are recognized appliances that operate on the R32 refrigerant. They are available with several capacities, while maintaining high energy efficiency. Moreover, the system operates based on the inverter technology that contributes to lower energy consumption. The slim and simple design of C1 air conditioners makes them a perfect choice for homes, offices and business.

TEMPERATURE SETPOINT from 16 to 30°C



High energy efficiency

Innovative solutions enabled a significant reduction of energy consumption in both cooling and heating mode. The appliances have A++/A+ energy rating.



Quick and easy installation

The design of the air conditioners and new technological solutions enable trouble-free and efficient installation. Easier access, increased installation space and right- and left-sided connection options reduce the installation time to as little as 40 min.



R32 refrigerant

The R32 refrigerant used in Split air conditioners makes them far more efficient than the appliances operating on the commonly used R410A refrigerant.



SMART airflow

An innovative solution for airflow control. The stream is directed upwards during the cooling and downwards during the heating, which enables an even distribution of air, thus preventing direct airflow on the user.



Quiet operation

The components comprising the air conditioner and the optimum airflow system ensure quiet operation for comfort during work and leisure.





Indoor unit



Wireless controller
YR-HAC01 (included)

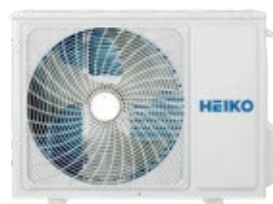

Outdoor unit

Indoor unit		JS035-C1	
Outdoor unit		JZ035-C1	
Capacity (cooling)	Rated (min. – max)	Btu/h	11944 (2730 – 12620)
	Rated (min. – max)	kW	3.5 (0.8–3.7)
Energy efficiency	SEER/EER		6.1/2.81
Energy rating	Cooling		A++
Power input (cooling)	Nom. (min. – max)	kW	1.24 (0.30–1.60)
Annual energy consumption (cooling)		kWh/r	201
Capacity (heating)	Nom. (min. – max)	Btu/h	12280 (2730 – 14330)
	Heating -7°C	Btu/h	8463
	Nom. (min. – max)	kW	3.6 (0.8–4.2)
	Heating -7°C	kW	2.48
Energy efficiency	SCOP/COP (moderate climate)		4.0/3.41
	SCOP (warm/cold climate)		5.1/-
Energy rating (heating)	Moderate/warm/cold climate		A+/A+++/-
Power input (heating)	Nom. (min. – max)	kW	1.05 (0.30–1.60)
Annual energy consumption (heating)		kWh/r	980
Operating range (cooling)	Min. – max (out)	°C	-10–43
Operating range (heating)	Min. – max (out)	°C	-15–24
Power supply		f/V/Hz	1/230/50
Power supply (position)			jednostka wewnętrzna
Indoor unit		JS035-C1	
Package dimensions	W/D/H	mm	820/195/280
Dimensions with packaging	W/D/H	mm	909/279/355
Net/gross weight		kg	8.2/10.5
Performance (cooling/heating)	Max	m³/h	550
Sound power level	Max	dB(A)	56
Sound pressure level		dB(A)	37/33/29/19
Moisture removal capacity		10 ⁻³ m³/h	1.6
Outdoor unit		JZ035-C1	
Compressor			Hitachi
Net dimensions	W/D/H	mm	700/245/544
Packaging dimensions	W/D/H	mm	845/320/593
Net/gross weight		kg	22.8/25.3
Performance (cooling/heating)	Max	m³/h	2100
Sound power level		dB(A)	62
Sound pressure level		dB(A)	50
Operating current	Max	A	7.1
Refrigerant filling	Refrigerant type		R32
	Refrigerant filling	g	500
Refrigerant piping	Liquid pipe diameter	mm	6.35
	Gas pipe diameter	mm	9.52
	Max pipeline length/Max level difference	m	15/10
	Max pipeline length without additional filling	m	5
	Extra refrigerant per metre of pipeline	g/m	20

SPLIT

Cassette air conditioners with 4-way airflow

Heiko cassette air conditioners are a great solution for installation at homes, offices or restaurants. The product range includes appliances with different capacity to suit the size of building area. Cassette air conditioners are available with 4-way airflow (option). Heiko appliances are discrete, installer-friendly and perfectly match any interior design.

TEMPERATURE SETPOINT from 16 to 30°C



High energy efficiency

Innovative solutions enabled a significant reduction of energy consumption in both cooling and heating mode. The appliances have A+++/A+ energy rating.



SMART airflow

An innovative solution for airflow control. The stream is directed upwards during the cooling and downwards during the heating, which enables an even distribution of air, thus preventing direct airflow on the user.



Airflow speed control

The option to control airflow shutters vertically enables precise direction of the airflow. The function is available from the controller.



Quiet operation

The components comprising the air conditioner and the optimum airflow system ensure quiet operation for comfort during work and leisure.





Indoor unit



Cover
PB-700HE4
(option)



Wireless controller
YR-HRC01 or YR-NRS01
(option)



Wired controller
YR-C01 or YR-C01A
(option)

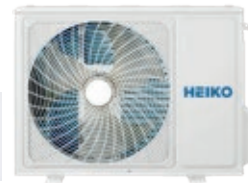

Outdoor unit

Indoor unit		CA035-A1		CA050-A1	
Outdoor unit		JZ035-A1		JZ050-A1	
Rated value	Capacity	- Cooling	Btu/h (nom.)	12000	17000
			kW nom. (min.~max)	3.50 (0.9-4.5)	5.0 (1.8-5.8)
	- Heating	Btu/h (nom.)	12600	18800	
		kW nom. (min. ~ max)	4.0 (1-4.8)	5.5 (2-6.5)	
Power input	- Cooling	kW nom. (min. ~ max)	1.06 (0.28-1.8)	1.53 (0.55-2)	
		- Heating	kW nom. (min. ~ max)	0.99 (0.28-1.8)	1.52 (0.6-2)
	EER/COP		3.31/3.71	3.26/3.42	
	SEER/SCOP		6.1/3.8	6.1/3.8	
Season value	Energy rating (cooling/heating)		A++/A	A++/A	
	Annual energy consumption (cooling)		kWh	222	363
	Annual energy consumption (heating)		kWh	1427	1932
Indoor unit		CA035-A1		CA050-A1	
Electrical parameters	Power supply	f/V/Hz		1/220-240/50/60	1/220-240/50/60
Performance	Airflow	m³/h		620/520/450	700/620/500
	Sound power level	dB(A)		52	55
	Sound pressure level	dB(A)		36/33/30	42/37/35
Installation	Dimensions without packaging (W/D/H)		mm	570/570/260	570/570/260
	Dimensions with packaging (W/D/H)		mm	718/680/380	718/680/380
	Net/gross weight		kg	18.5/22	19/22
	Controller	wireless option	YR-HRC01 / YR-NRS01	YR-HRC01 / YR-NRS01	YR-HRC01 / YR-NRS01
		wired option	YR-C01 / YR-C01A	YR-C01 / YR-C01A	
Cover	Model	option		PB-700HE4	PB-700HE4
	Dimensions (W/D/H)		mm	700/700/60	700/700/60
	Dimensions with packaging (W/D/H)		mm	740/750/115	740/750/115
	Net/gross weight		kg	2.8/4.8	2.8/4.8
Outdoor unit		JZ035-A1		JZ050-A1	
Electrical parameters	Power supply	f/V/Hz		1/230/50	1/230/50
Performance	Airflow (h)	m³/h		2000	2500
	Sound power level	dB(A)		61	63
	Sound pressure level	dB(A)		48	51
Installation	Dimensions without packaging (W/D/H)		mm	800/275/553	820/338/614
	Dimensions with packaging (W/D/H)		mm	954/409/625	993/413/685
	Net/gross weight		kg	31.5/34	37.8/41.5
	Compressor type			Rotary	Rotary
	Refrigerant			R32	R32
	GWP			675	675
	Liquid pipe diameter		mm	6.35	6.35
	Gas pipe diameter		mm	9.52	12.7
	Total pipeline length (max)		m	15	25
	Max level difference		m	10	15
Working conditions (out)	Refrigerant filling		kg	0.94	0.95
	Total pipeline length without refill		m	7	7
	Extra refrigerant per metre of pipeline		g/m	20	20
	Cooling (min - max)		°C	-10~43	-10~43
	Heating (min. - max)		°C	-15~24	-15~24

SPLIT

Cassette air conditioners with peripheral airflow

Heiko cassette air conditioners are a great solution for installation at homes, offices or restaurants. The product range includes appliances with different capacity to suit the size of building area. Cassette air conditioners are available with a panel for peripheral airflow. Heiko appliances are discrete, installer-friendly and perfectly match any interior design.

TEMPERATURE SETPOINT from 16 to 30°C



Peripheral airflow

With the 360-degree cover, the air is supplied from four sides and corners to ensure efficient airflow in the room.



High energy efficiency

Innovative solutions enabled a significant reduction of energy consumption in both cooling and heating mode. The appliances have A++/A energy rating.



SMART airflow

An innovative solution for airflow control. The stream is directed upwards during the cooling and downwards during the heating, which enables an even distribution of air, thus preventing direct airflow on the user.



Airflow speed control

The option to control airflow shutters vertically enables precise direction of the airflow. The function is available from the controller.



Quiet operation

The components comprising the air conditioner and the optimum airflow system ensure quiet operation for comfort during work and leisure.

TURBO MODE

ONE-TOUCH
FULL POWER

SLEEP FUNCTION

MAKE YOUR
SLEEP
COMFORTABLE

AUTO COOLING HEATING DRYING FAN



Indoor unit



Cover
PB-950HE4
(option)



Wireless controller
YR-HRC01 or YR-NRS01
(option)



Wired controller
YR-C01 or YR-C01A
(option)

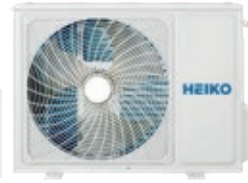

Outdoor unit

Indoor unit		CA070-A1		CA100-A1	
Outdoor unit		JZ070-A1		JZ100-A1	
Rated value	Capacity	- Cooling	Btu/h (nom.)	22200	31400
			kW nom. (min.~max)	7.1 (2-7.3)	9.2 (2.5-10.0)
	Power input	- Heating	Btu/h (nom.)	24300	34800
			kW nom. (min. ~ max)	8.0 (2.5-8)	10.2 (3.0-10.5)
	EER/COP	- Cooling	kW nom. (min. ~ max)	2.20 (0.5-2.6)	3.12 (0.5-4.0)
		- Heating	kW nom. (min. ~ max)	1.91 (0.5-2.6)	2.91 (0.5-4.0)
Season value	SEER/SCOP			3.23/3.72	3/3.5
	Energy rating (cooling/heating)			6.1/3.8	5.9/3.8
	Annual energy consumption (cooling)		kWh	406	555
	Annual energy consumption (heating)		kWh	1831	2780
Indoor unit		CA070-A1		CA100-A1	
Electrical parameters	Power supply		f/V/Hz	1/220-240/50/60	1/220-240/50/60
Performance	Airflow		m³/h	1260/1070/820/680	1680/1530/1320/1190
	Sound power level		dB(A)	55	62
	Sound pressure level		dB(A)	42/40/38/35	45/42/38/34
Installation	Dimensions without packaging (W/D/H)		mm	840/840/204	840/840/246
	Dimensions with packaging (W/D/H)		mm	990/990/310	990/990/310
	Net/gross weight		kg	27/32	31/36
Cover	Model	wireless option		YR-HRC01 / YR-NRS01	YR-HRC01 / YR-NRS01
		wired option		YR-C01 / YR-C01A	YR-C01 / YR-C01A
Cover	Dimensions (W/D/H)	option		PB-950HE4	PB-950HE4
			mm	950/950/50	950/950/50
			mm	1000/1000/110	1000/1000/110
	Net/gross weight		kg	6.5/9	6.5/9
Outdoor unit		JZ070-A1		JZ100-A1	
Electrical parameters	Power supply		f/V/Hz	1/220-240/50/60	1/220-240/50/60
Performance	Airflow (h)		m³/h	3000	3500
	Sound power level		dB(A)	67	66
	Sound pressure level		dB(A)	54	53
Installation	Dimensions without packaging (W/D/H)		mm	890/353/697	920/372/760
	Dimensions with packaging (W/D/H)		mm	1046/460/780	1036/478/820
	Net/gross weight		kg	48/53	60/65
	Compressor type			Twin rotary	Twin rotary
	Refrigerant			R32	R32
	GWP			675	675
	Liquid pipe diameter		mm	9.52	9.52
	Gas pipe diameter		mm	15.88	15.88
	Total pipeline length (max)		m	50	50
	Max level difference		m	30	30
	Refrigerant filling		kg	1.3	1.5
	Total pipeline length without refill		m	10	30
	Extra refrigerant per metre of pipeline		g/m	45	45
Working conditions (out)	Cooling (min - max)		°C	-10~46	-10~46
	Heating (min. - max)		°C	-15~24	-15~24

Mobile air conditioners

Compact appliances in sophisticated style, with 4 operating modes: cooling, heating, drying and air supply. The air conditioners are equipped with wheels and carrying handles for easy handling. The appliances are controlled with an advanced panel or a wireless controller.

Wireless controller included.



Full control

Filter cleaning notification (icon on the display) after 250 operating hours.



4 operations modes

Comprehensive application of the appliance for cooling, air supply, drying or heating.



Swing function

Shutter swinging for air distribution as needed.



Timer

The air conditioner has the function to set the operation time. The operation of the appliance will start or end at the programmed time.





Wireless controller
(included)

Indoor unit		AM12HEIA4	
Power supply		f/V/Hz	1/220-240V/50 Hz
Cooling	Rated capacity	W	3400
	EER	W/W	2.6
	Rated power consumption	W	1300
	Rated current	A	5.80
Heating	Rated capacity	W	2700
	COP	W/W	2.7
	Rated power consumption	W	1000
	Rated current	A	4.60
Maximum power input		W	1450
Maximum current		A	8.00
Starting current		A	/
Plug type		A	16
Compressor	Model		DSM215V2UDZ
	Type		Rotary
	Brand		GMCC
	Capacity	Btu/h	10918
	Input	W	985
Internal fan motor	Model		YDK15-6
	Brand		WELLING
	Input	W	52.5
	Capacitor	μF	1.5
	Speed (high/mid/low)	rpm	630/570/490
Internal Performance	(high/mid/low)	m ³ /h	390/360/330
Sound power level	(high/mid/low)	dB(A)	64/63.5/63
External fan motor	Model		YDK45-4
	Brand		WELLING
	Input	W	119
	Capacitor	μF	3.5
	Speed	rpm	1130
External Performance		m ³ /h	550
Unit dimensions	(W x H x D)	mm	476*710*385
Packaging dimensions	(W x H x D)	mm	545*885*435
Net/gross weight		kg	33.5/38.5
Refrigerant			R290

MULTI SPLIT Air conditioning systems



High energy efficiency

HEIKO air conditioning systems are energy-saving devices that, in addition to the basic cooling function, also have the option of heating the room. They are great for home and commercial facilities.

Device operation

The operation of the device is simple and intuitive. Most wall units come with a Wi-Fi module as standard. Control is facilitated by a wireless remote control or a wired controller. A dedicated application for mobile devices allows remote control of the device.

Design

HEIKO air conditioners will perfectly fit into any interior. Their timeless design will make them stand out additional element of room decor.

User comfort

Out of concern for the comfort of use, the air conditioners are equipped with components that guarantee quiet operation of the device. This allows for a peaceful rest without unnecessary and burdensome noise.

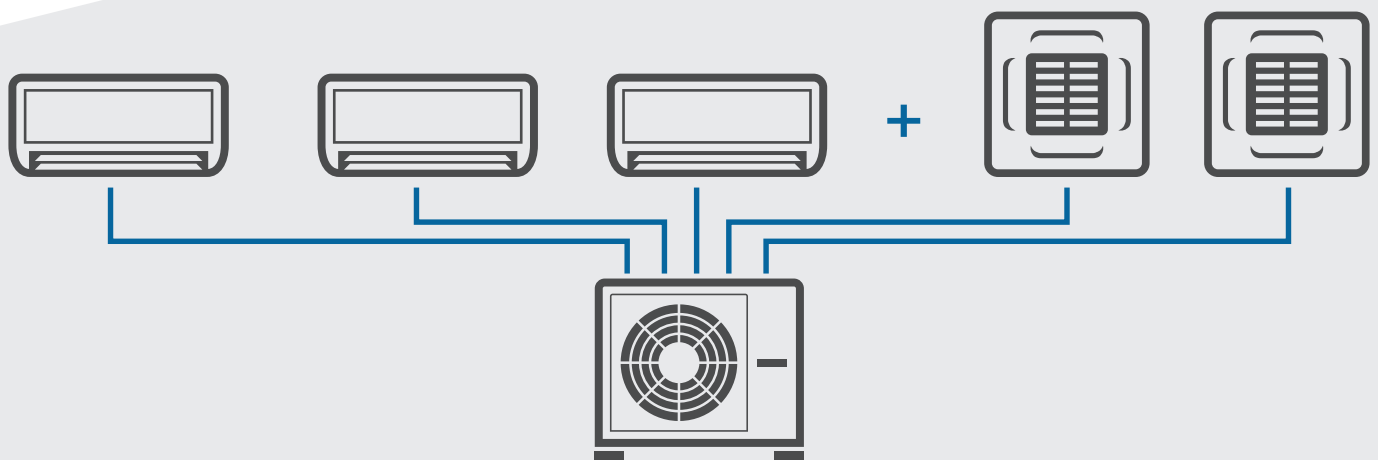





















Multi Split air conditioning systems consist of two to five indoor units that are installed indoors and one outdoor unit.

MULTI SPLIT

Models available

Outdoor units

Indoor and outdoor units	Refrigerant	Controller	
BRISA wall-mounted units			YR-HAC01 Wireless controller (included)
QIRA wall-mounted units			YR-HAC01 Wireless controller (included)
ARIA wall-mounted units			YR-HAC01 Wireless controller (included)
D1 wall-mounted units			YR-HAC01 Wireless controller (included)
D2 wall-mounted units			YR-HAC01 Wireless controller (included)
CASSETTE units with 4-way airflow		 Wireless controller YR-HRC01 (option)	 Wireless controller YR-NRS01 (option)
		 Wireless controller YR-C01 (option)	 Wireless controller YR-C01A (option)
CASSETTE units with peripheral airflow		 Wireless controller YR-HRC01 (option)	 Wireless controller YR-NRS01 (option)
		 Wireless controller YR-C01 (option)	 Wireless controller YR-C01A (option)

5,0 kW



M2T050-D1/M2T050-D2
(option to connect up to 2 indoor units)

7,0 kW



M3T070-D1
(option to connect up to 3 indoor units)

10,0 kW



M5T100-D1
(option to connect up to 5 indoor units)

2,5 kW



JS025-C2



JS025-QW2



JS025-A1

3,5 kW



JS035-C2



JS035-QW2



JS035-A1



JS035-D1



JS035-D2

5,0 kW



JS050-C2



JS050-QW2

7,0 kW



CA035-A1



CA050-A1



CA070-A1

MULTI SPLIT

Outdoor units



R32 refrigerant

The R32 refrigerant used in air conditioners makes them far more efficient than the appliances operating on the commonly used R410A refrigerant.



Inverter technology

The inverter technology enables economical operation of the system without sudden spikes in compressor frequency, while ensuring energy-efficient and quiet operation of the appliance.



Automatic defrosting

Efficient operation of the MULTI SPLIT system in the heating mode, under difficult weather conditions, is possible with automatic defrosting of the heat exchanger of the outdoor unit.



DC motor

The high-efficiency DC motor with a compact design ensures energy-efficient operation of the fan of the outdoor unit. The DC motor, compared to conventional AC motors, ensures lower operation noise of the outdoor unit.



Hydrophilic aluminum film

The special coating of heat exchangers prevents corrosion and extends the service life of the appliance.

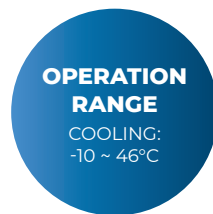



Outdoor unit			M2T050-D1	M3T070-D1	M5T100-D1
Electrical parameters	Power supply	f/V/Hz	1/230/50	1/220-240/50/60	1/220-240/50/60
Performance	Airflow	m ³ /h	2400	3000	4200
	Sound power level	dB(A)	63	66	71
	Sound pressure level	dB(A)	53	53	55
Installation	Dimensions without packaging (W/D/H)	mm	800/275/553	890/340/700	920/372/760
	Dimensions with packaging (W/D/H)	mm	954/409/625	998/443/770	1036/478/820
	Net/gross weight	kg	36/39	54/58	66/71
	Compressor type		Rotary	Twin rotary	Twin rotary
	Refrigerant		R32	R32	R32
	GWP		675	675	675
	Liquid pipe diameter	mm	2x6.35	3x6.35	5x6.35
	Gas pipe diameter	mm	2x9.52	3x9.52	3x9.52+2x12.7
	Total pipeline length (max)	m	30	60	80
	Max level difference	m	15	25	25
	Refrigerant filling	kg	1.4	1.6	2.4
Total pipeline length without filling	m	20	30	40	
Extra refrigerant per metre of pipeline	g/m	20	20	20	
Working conditions (out)	Cooling (min ~ max)	°C	-10~46	-10~46	-10~46
	Heating (min ~ max)	°C	-15~24	-15~24	-15~24

Outdoor unit			M2T050-D1	M3T070-D1	M5T100-D1
Max number of indoor units per outdoor unit			2	3	5
Indoor units			2*JS035-D2	3*JS026-D2	2*JS026-D2+JS035-D2+JS050-C2
Rated value	Cooling capacity	kW (rated (min. – max))	5 (1.1-5.7)	6.2	9.5
	Heating capacity	kW (rated (min. – max))	5.2 (1.6-6.1)	6.8	10.0
	Cooling power input	kW (rated (min. – max))	1.45 (0.35-2.55)	1.85	3.4
	Heating power input	kW (rated (min. – max))	1.4 (0.55-2.8)	2.05	2.8
	EER/COP		3.45/3.71	3.3/3.3	2.7/3.2
Season value	SEER/SCOP		6.50/4.00	6.2/3.8	6.2/3.8
	Energy rating (cooling/heating)		A++/A+	A++/A	A++/A
	Annual energy consumption (cooling)	kWh	269	332	537
	Annual energy consumption (heating)	kWh	1645	2012	2889

MULTI SPLIT

BRISA wall-mounted air conditioners

TEMPERATURE SETPOINT from 16 to 30°C



Wi-Fi control

The Wi-Fi control in standard enables controlling the air conditioner with your smartphone connected to the Internet from any place. The comfortable and intuitive Wi-Fi INTELLIGENT AIR app enables access to all basic settings of the air conditioner.



High energy efficiency

Innovative solutions enabled a significant reduction of energy consumption in both cooling and heating mode. The appliances have A++/A+ energy rating.



SMART airflow

An innovative solution for airflow control. The stream is directed upwards during the cooling and downwards during the heating, which enables an even distribution of air, thus preventing direct airflow on the user.



Airflow speed control

The option to control airflow shutters vertically and horizontally enables precise direction of the airflow. The up-down control function is available from the wireless controller and the Wi-Fi Intelligent Air app. The left-right control is done manually.



Quiet operation

The components comprising the air conditioner and the optimum airflow system ensure quiet operation for comfort during work and leisure.





Indoor unit



Wireless controller
YR-HAC01
(included)

Indoor unit			JS025-C2	JS035-C2	JS050-C2
Rated capacity	Cooling	kW	2,6	3,2	5,0
	Heating	kW	2,8	3,4	5,2
Electrical parameters	Power supply	f/V/Hz	1/220-240/50	1/220-240/50	1/220-240/50
Performance	Airflow	m ³ /h	500	550	900
	Sound power level	dB(A)	54	56	57
	Sound pressure level	dB(A)	37/33/29/19	38/34/29/20	44/40/35/28
Installation	Dimensions without packaging (W/D/H)	mm	820/195/280	820/195/280	1008/225/318
	Dimensions with packaging (W/D/H)	mm	909/279/355	909/279/355	1085/329/403
	Net/gross weight	kg	8.2/10.5	8.2/10.5	11.6/14.4
	Liquid pipe diameter	mm	6,35	6,35	6,35
	Gas pipe diameter	mm	9,52	9,52	12,7
	Controller	Standard	YR-HAC01	YR-HAC01	YR-HAC01

MULTI SPLIT

QIRA wall-mounted air Conditioners

NEW

TEMPERATURE SETPOINT from 16 to 30°C



Ionizer

The ionizer improves air quality in the room. Electrical equipment generates positive ions, also referred to as electro smog, that attract dust and viruses. Negative ions are generated by the ionizer neutralize the charge of positive ions by causing the contaminants to fall on the floor, while reducing the risk of allergy and various infections. The ionizer also helps neutralizing the odors in the room.



Wi-Fi control

The Wi-Fi control in standard enables controlling the air conditioner with your smartphone connected to the Internet from any place. The comfortable and intuitive Wi-Fi INTELLIGENT AIR app enables access to all basic settings of the air conditioner.



High energy efficiency

Innovative solutions enabled a significant reduction of energy consumption in both cooling and heating mode. The appliances have A++/A+ energy rating.



SMART airflow

An innovative solution for airflow control. The stream is directed upwards during the cooling and downwards during the heating, which enables an even distribution of air, thus preventing direct airflow on the user.



Airflow speed control

The option to control airflow shutters vertically and horizontally enables precise direction of the airflow. The up-down and left-right control functions are available from the wireless controller and the Wi-Fi Intelligent Air app.





Indoor unit



Wireless controller
YR-HAC01
(included)

Indoor unit			JS025-QW2	JS035-QW2	JS050-QW2
Rated capacity	Cooling	kW	2,6	3,5	5,0
	Heating	kW	2,8	3,5	5,2
Electrical parameters	Power supply	f/V/Hz	1/220-240/50	1/220-240/50	1/220-240/50
Performance	Airflow	m ³ /h	550	600	900
	Sound power level	dB(A)	54	56	57
	Sound pressure level	dB(A)	37/32/28/18	37/33/29/19	44/40/35/28
Installation	Dimensions without packaging (W/D/H)	mm	805/200/290	805/200/290	975/220/320
	Dimensions with packaging (W/D/H)	mm	874/270/363	874/270/363	1050/301/397
	Net/gross weight	kg	8.3/10.5	8.3/10.5	11.6/14.4
	Liquid pipe diameter	mm	6,35	6,35	6,35
	Gas pipe diameter	mm	9,52	9,52	12,7
	Controller	Standard	YR-HAC01	YR-HAC01	YR-HAC01

MULTI SPLIT

ARIA wall-mounted air conditioners

TEMPERATURE SETPOINT from 16 to 30°C



Ionizer

The ionizer improves air quality in the room. Electrical equipment generates positive ions, also referred to as electro smog, that attract dust and viruses. Negative ions are generated by the ionizer neutralize the charge of positive ions by causing the contaminants to fall on the floor, while reducing the risk of allergy and various infections. The ionizer also helps neutralizing the odors in the room.



Wi-Fi control

The Wi-Fi control in standard enables controlling the air conditioner with your smartphone connected to the Internet from any place. The comfortable and intuitive Wi-Fi INTELLIGENT AIR app enables access to all basic settings of the air conditioner.



High energy efficiency

Innovative solutions enabled a significant reduction of energy consumption in both cooling and heating mode. The appliances have A+++/A+ energy rating.



SMART airflow

An innovative solution for airflow control. The stream is directed upwards during the cooling and downwards during the heating, which enables an even distribution of air, thus preventing direct airflow on the user.



Airflow speed control

The option to control airflow shutters vertically and horizontally enables precise direction of the airflow. The up-down and left-right control functions are available from the wireless controller and the Wi-Fi Intelligent Air app

TURBO MODE

ONE-TOUCH
FULL POWER

SLEEP FUNCTION

MAKE YOUR
SLEEP
COMFORTABLE

AUTO COOLING HEATING DRYING FAN





Indoor unit



Wireless controller
YR-HAC01
(included)

Indoor unit			JS025-A1	JS035-A1
Rated capacity	Cooling	kW	2,6	3,5
	Heating	kW	3,2	4,2
Electrical parameters	Power supply	f/V/Hz	1/230/50	1/230/50
Performance	Airflow	m ³ /h	600	650
	Sound power level	dB(A)	53	55
	Sound pressure level	dB(A)	38/32/25/19	39/33/26/20
Installation	Dimensions without packaging (W/D/H)	mm	870/196/301	870/196/301
	Dimensions with packaging (W/D/H)	mm	952/283/389	952/283/389
	Net/gross weight	kg	9.5/12	9.5/12
	Liquid pipe diameter	mm	6,35	6,35
	Gas pipe diameter	mm	9,52	9,52
	Controller	Standard	YR-HAC01	YR-HAC01

MULTI SPLIT D1 wall-mounted air conditioners

TEMPERATURE SETPOINT from 16 to 30°C



High energy efficiency

Innovative solutions enabled a significant reduction of energy consumption in both cooling and heating mode. The appliances have A++/A+ energy rating.



Quick and easy installation

The design of the air conditioners and new technological solutions enable trouble-free and efficient installation. Easier access, increased installation space and right- and left-sided connection options reduce the installation time to as little as 40 min.



R32 refrigerant

The R32 refrigerant used in Split air conditioners makes them far more efficient than the appliances operating on the commonly used R410A refrigerant.



SMART airflow

An innovative solution for airflow control. The stream is directed upwards during the cooling and downwards during the heating, which enables an even distribution of air, thus preventing direct airflow on the user.



Quiet operation

The components comprising the air conditioner and the optimum airflow system ensure quiet operation for comfort during work and leisure.





Indoor unit



Wireless controller
YR-HAC01
(included)

Indoor unit		JS035-D1	
Rated capacity	Cooling	kW	3,6
	Heating	kW	3,7
Electrical parameters	Power supply	f/V/Hz	1/230/50
Performance	Airflow	m ³ /h	550
	Sound power level	dB(A)	55
	Sound pressure level	dB(A)	38/33/29/21
Installation	Dimensions without packaging (W/D/H)	mm	820/195/280
	Dimensions with packaging (W/D/H)	mm	909/279/355
	Net/gross weight	kg	8.4/10.5
	Liquid pipe diameter	mm	6,35
	Gas pipe diameter	mm	9,52
Controller	Standard		YR-HAC01

MULTI SPLIT

D2 wall-mounted air conditioners

TEMPERATURE SETPOINT from 16 to 30°C



Wi-Fi control

The Wi-Fi control in standard enables controlling the air conditioner with your smartphone connected to the Internet from any place. The comfortable and intuitive Wi-Fi INTELLIGENT AIR app enables access to all basic settings of the air conditioner.



High energy efficiency

Innovative solutions enabled a significant reduction of energy consumption in both cooling and heating mode. The appliances have A++/A+ energy rating.



R32 refrigerant

The R32 refrigerant used in Split air conditioners makes them far more efficient than the appliances operating on the commonly used R410A refrigerant.



SMART airflow

An innovative solution for airflow control. The stream is directed upwards during the cooling and downwards during the heating, which enables an even distribution of air, thus preventing direct airflow on the user.



Quiet operation

The components comprising the air conditioner and the optimum airflow system ensure quiet operation for comfort during work and leisure.





Indoor unit



Wireless controller
YR-HAC01
(included)

Indoor unit		JS035-D2	
Rated capacity	Cooling	kW	3,6
	Heating	kW	3,7
Electrical parameters	Power supply	f/V/Hz	1/230/50
Performance	Airflow	m ³ /h	550
	Sound power level	dB(A)	55
	Sound pressure level	dB(A)	38/33/29/21
Installation	Dimensions without packaging (W/D/H)	mm	820/195/280
	Dimensions with packaging (W/D/H)	mm	909/279/355
	Net/gross weight	kg	8.4/10.5
	Liquid pipe diameter	mm	6,35
	Gas pipe diameter	mm	9,52
Controller	Standard		YR-HAC01

MULTI SPLIT

Cassette air conditioners

with 4-way airflow

TEMPERATURE SETPOINT from 16 to 30°C



High energy efficiency

Innovative solutions enabled a significant reduction of energy consumption in both cooling and heating mode. The appliances have A+++/A+ energy rating.



SMART airflow

An innovative solution for airflow control. The stream is directed upwards during the cooling and downwards during the heating, which enables an even distribution of air, thus preventing direct airflow on the user.



Airflow speed control

The option to control airflow shutters vertically enables precise direction of the airflow. The function is available from the controller.



Quiet operation

The components comprising the air conditioner and the optimum airflow system ensure quiet operation for comfort during work and leisure.





Indoor unit



Cover
PB-700HE4
(option)



Wireless controller
YR-HRC01 or YR-NRS01
(option)



Wired controller
YR-C01 or YR-C01A
(option)

Indoor unit			CA035-A1	CA050-A1
Rated capacity	Cooling	kW	3.5	5
	Heating	kW	4.0	5,5
Electrical parameters	Power supply	f/V/Hz	1/220-240/50/60	1/220-240/50/60
Performance	Airflow	m ³ /h	620/520/420/350	700/600/500/400
	Sound power level	dB(A)	52	57
	Sound pressure level	dB(A)	35/32/30/28	42/37/35/31
Installation	Dimensions without packaging (W/D/H)	mm	570/570/260	570/570/260
	Dimensions with packaging (W/D/H)	mm	718/680/380	718/680/380
	Net/gross weight	kg	18.5/22	18.5/22
	Liquid pipe diameter	mm	6,35	6,35
	Gas pipe diameter	mm	9,52	12,7
Controller	Wireless option		YR-HRC01 / YR-NRS01	YR-HRC01 / YR-NRS01
	Wired option		YR-C01 / YR-C01A	YR-C01 / YR-C01A
Cover	Type	Option	PB-700HE4	PB-700HE4
	Dimensions without packaging (W/D/H)	mm	700/700/60	700/700/60
	Dimensions with packaging (W/D/H)	mm	740/750/115	740/750/115
	Net/gross weight	kg	2.8/4.8	2.8/4.8

MULTI SPLIT

Cassette air conditioners with peripheral airflow

TEMPERATURE SETPOINT from 16 to 30°C



Peripheral airflow

With the 360-degree cover, the air is supplied from four sides and corners to ensure efficient airflow in the room.



High energy efficiency

Innovative solutions enabled a significant reduction of energy consumption in both cooling and heating mode. The appliances have A++/A energy rating.



SMART airflow

An innovative solution for airflow control. The stream is directed upwards during the cooling and downwards during the heating, which enables an even distribution of air, thus preventing direct airflow on the user.



Airflow speed control

The option to control airflow shutters vertically enables precise direction of the airflow. The function is available from the controller.



Quiet operation

The components comprising the air conditioner and the optimum airflow system ensure quiet operation for comfort during work and leisure.

TURBO MODE

ONE-TOUCH
FULL POWER

SLEEP FUNCTION

MAKE YOUR
SLEEP
COMFORTABLE

AUTO COOLING HEATING DRYING FAN





Indoor unit



Cover
PB-950HE4
(option)



Wireless controller
YR-HRC01 or YR-NRS01
(option)



Wired controller
YR-C01 or YR-C01A
(option)

Indoor unit		CA070-A1	
Rated capacity	Cooling	kW	7,1
	Heating	kW	8
Electrical parameters	Power supply	f/V/Hz	1/220-240/50/60
Performance	Airflow	m ³ /h	1260/1070/820/680
	Sound power level	dB(A)	55
	Sound pressure level	dB(A)	36/33/29/26
Installation	Dimensions without packaging (W/D/H)	mm	840/840/204
	Dimensions with packaging (W/D/H)	mm	990/990/310
	Net/gross weight	kg	27/31
	Liquid pipe diameter	mm	9,52
	Gas pipe diameter	mm	15,88
	Controller	Wireless option	YR-HRC01 / YR-NRS01
	Wired option	YR-C01 / YR-C01A	
Cover	Type	Option	PB-950HE4
	Dimensions without packaging (W/D/H)	mm	950/950/50
	Dimensions with packaging (W/D/H)	mm	1000/1000/110
	Net/gross weight	kg	6.5/9

MULTI SPLIT Combinations

M2T050-D1

COOLING									
Comb.	Combinations			Rated capacity (kW)			Total cooling capacity (kW)		
	Unit A	Unit B	Unit C	Unit A	Unit B	Unit C	Min data	Rated data	Max data
1:2	2.5	2.5	---	2.50	2.50	---	1.10	5.00	5.60
	2.5	3.5	---	2.20	2.80	---	1.10	5.00	5.60

HEATING									
Comb.	Combinations			Rated capacity (kW)			Total heating capacity (kW)		
	Unit A	Unit B	Unit C	Unit A	Unit B	Unit C	Min data	Rated data	Max data
1:2	2.5	2.5	---	2.60	2.60	---	1.40	5.20	6.00
	2.5	3.5	---	2.50	2.70	---	1.50	5.20	6.10

M3T070-D1

COOLING									
Comb.	Combinations			Rated capacity (kW)			Total cooling capacity (kW)		
	Unit A	Unit B	Unit C	Unit A	Unit B	Unit C	Min data	Rated data	Max data
1:1	2.5	—	—	2.60	—	—	0.80	2.60	3.90
	3.5	—	—	3.60	—	—	1.00	3.60	5.30
	5.0	—	—	5.20	—	—	1.40	5.20	7.00
	7.0	—	—	6.50	—	—	1.50	6.50	7.40
1:2	2.5	2.5	—	2.60	2.60	—	2.00	5.20	7.40
	2.5	3.5	—	2.60	3.60	—	2.00	6.20	7.60
	2.5	5.0	—	2.33	4.67	—	2.40	7.00	7.60
	3.5	3.5	—	3.40	3.40	—	2.40	6.80	7.60
	3.5	5.0	—	2.86	4.14	—	2.40	7.00	7.60
1:3	2.5	2.5	2.5	2.33	2.33	2.33	2.40	7.00	7.60
	2.5	2.5	3.5	2.07	2.07	2.86	2.40	7.00	7.60
	2.5	3.5	3.5	1.86	2.57	2.57	2.40	7.00	7.60

HEATING									
Comb.	Combinations			Rated capacity (kW)			Total heating capacity (kW)		
	Unit A	Unit B	Unit C	Unit A	Unit B	Unit C	Min data	Rated data	Max data
1:1	2.5	—	—	3.60	—	—	0.80	3.60	6.00
	3.5	—	—	4.50	—	—	1.00	4.50	6.00
	5.0	—	—	6.00	—	—	1.50	6.00	8.00
	7.0	—	—	7.00	—	—	1.50	7.00	8.60
1:2	2.5	2.5	—	3.60	3.60	—	2.90	7.20	8.50
	2.5	3.5	—	3.38	4.22	—	2.90	7.60	8.50
	2.5	5.0	—	2.85	4.75	—	2.90	7.60	8.50
	3.5	3.5	—	3.75	3.75	—	2.90	7.50	8.50
	3.5	5.0	—	3.26	4.34	—	2.90	7.60	8.50
1:3	2.5	2.5	2.5	2.53	2.53	2.53	2.90	7.60	8.50
	2.5	2.5	3.5	2.34	2.34	2.92	2.90	7.60	8.50
	2.5	3.5	3.5	2.17	2.71	2.71	2.90	7.60	8.50

Technical specifications

Power input (kW)			Total current (A) at 230 V			EER	Class label	SEER (W/W)	Class label
Min data	Rated data	Max data	Min data	Rated data	Max data			Rated cap.	
0.35	1.43	2.51	1.6	6.3	11.3	3.50	A	6.50	A++
0.35	1.39	2.52	1.6	6.2	11.3	3.60	A	6.50	A++

Power input (kW)			Total current (A) at 230 V			COP	Class label	SCOP (W/W)	Class label
Min data	Rated data	Max data	Min data	Rated data	Max data			Rated cap.	
0.52	1.40	2.76	2.3	6.9	12.4	3.71	A	4.00	A+
0.53	1.40	2.77	2.4	6.9	12.4	3.71	A	4.00	A+

Power input (kW)			Total current (A) at 230 V			EER (W/W)	Class label	SEER (W/W)	Class label
Min data	Rated data	Max data	Min data	Rated data	Max data	Rated cap.		Rated cap.	
0.55	0.79	1.34	2.44	3.50	5.9	—	—	—	—
0.55	1.09	1.65	2.44	4.84	7.3	—	—	—	—
0.55	1.55	2.00	2.44	6.88	8.9	—	—	—	—
0.55	1.92	2.60	2.44	8.52	11.5	—	—	—	—
0.55	1.52	2.68	2.44	6.74	11.9	3.42	A	6.70	A++
0.55	1.79	2.99	2.44	7.94	13.3	3.46	A	6.70	A++
0.55	2.00	3.00	2.44	8.87	13.3	3.50	A	6.70	A++
0.55	2.00	3.20	2.44	8.87	14.2	3.40	A	6.20	A++
0.55	1.82	3.20	2.44	8.07	14.2	3.85	A	6.80	A++
0.55	1.76	2.70	2.44	7.81	12.0	3.98	A	7.50	A++
0.55	1.78	2.70	2.44	7.90	12.0	3.93	A	7.50	A++
0.55	1.78	2.70	2.44	7.90	12.0	3.93	A	7.50	A++

Power input (kW)			Total current (A) at 230 V			COP (W/W)	Class label	SCOP (W/W)	Class label
Min data	Rated data	Max data	Min data	Rated data	Max data	Rated cap.		Rated cap.	
0.55	0.98	1.50	2.44	4.35	6.65	—	—	—	—
0.55	1.22	1.65	2.44	5.41	7.32	—	—	—	—
0.55	1.60	2.00	2.44	7.10	8.87	—	—	—	—
0.55	1.84	2.20	2.44	8.16	9.76	—	—	—	—
0.55	1.93	2.10	2.44	8.56	9.32	3.73	A	3.90	A
0.55	2.05	2.10	2.44	9.09	9.32	3.71	A	3.90	A
0.55	2.05	2.10	2.44	9.09	9.32	3.71	A	3.95	A
0.55	1.93	2.20	2.44	8.54	9.76	3.90	A	3.80	A
0.55	2.00	2.20	2.44	8.87	9.76	3.80	A	4.00	A+
0.55	1.81	2.30	2.44	8.03	10.20	4.20	A	4.20	A+
0.55	1.84	2.30	2.44	8.16	10.20	4.13	A	4.20	A+
0.55	1.84	2.30	2.44	8.16	10.20	4.13	A	4.20	A+

MULTI SPLIT Combinations

M5T100-D1

CHŁODZENIE													
Komb.	Kombinacje					Wydajność znamionowa (kW)					Całkowita moc chłodnicza (kW)		
	Jed. A	Jed. B	Jed. C	Jed. D	Jed. E	Jed. A	Jed. B	Jed. C	Jed. D	Jed. E	Dane min.	Dane znam.	Dane max.
1:1	2.5	–	–	–	–	2.60	–	–	–	–	0.80	2.60	3.90
	3.5	–	–	–	–	3.60	–	–	–	–	1.00	3.60	5.30
	5.0	–	–	–	–	5.20	–	–	–	–	1.40	5.20	7.00
	7.0	–	–	–	–	6.50	–	–	–	–	1.50	6.50	7.40
1:2	2.5	2.5	–	–	–	2.60	2.60	–	–	–	2.50	5.20	7.80
	2.5	3.5	–	–	–	2.60	3.60	–	–	–	2.50	6.20	9.10
	2.5	5.0	–	–	–	2.60	5.20	–	–	–	2.50	7.80	9.30
	2.5	7.0	–	–	–	2.60	6.50	–	–	–	2.50	9.10	9.30
	3.5	3.5	–	–	–	3.60	3.60	–	–	–	2.50	7.20	9.30
	3.5	5.0	–	–	–	3.60	5.20	–	–	–	2.50	8.80	10.00
	3.5	7.0	–	–	–	3.56	6.44	–	–	–	2.50	10.00	11.00
	5.0	5.0	–	–	–	5.00	5.00	–	–	–	2.50	10.00	11.00
1:3	5.0	7.0	–	–	–	4.44	5.56	–	–	–	2.50	9.00	11.00
	7.0	7.0	–	–	–	5.00	5.00	–	–	–	2.50	10.00	11.00
	2.5	2.5	2.5	–	–	2.60	2.60	2.60	–	–	3.20	7.80	9.50
	2.5	2.5	3.5	–	–	2.60	2.60	3.60	–	–	3.20	8.80	10.00
	2.5	2.5	5.0	–	–	2.50	2.50	5.00	–	–	3.20	10.00	11.00
	2.5	2.5	7.0	–	–	2.22	2.22	5.56	–	–	3.20	10.00	11.00
	2.5	3.5	3.5	–	–	2.60	3.60	3.60	–	–	3.20	9.80	11.00
	2.5	3.5	5.0	–	–	2.28	3.16	4.56	–	–	3.20	10.00	11.00
	2.5	3.5	7.0	–	–	2.05	2.83	5.12	–	–	3.20	10.00	11.00
	2.5	5.0	5.0	–	–	2.00	4.00	4.00	–	–	3.20	10.00	11.00
1:4	3.5	3.5	3.5	–	–	3.33	3.33	3.33	–	–	3.20	10.00	11.00
	3.5	3.5	5.0	–	–	2.90	2.90	4.19	–	–	3.20	10.00	11.00
	3.5	5.0	5.0	–	–	2.57	3.71	3.71	–	–	3.20	10.00	11.00
	2.5	2.5	2.5	2.5	–	2.50	2.50	2.50	2.50	–	3.20	10.00	11.00
	2.5	2.5	2.5	3.5	–	2.28	2.28	2.28	3.16	–	3.20	10.00	11.00
	2.5	2.5	2.5	5.0	–	2.00	2.00	2.00	4.00	–	3.20	10.00	11.00
	2.5	2.5	2.5	7.0	–	1.82	1.82	1.82	4.55	–	3.20	10.00	11.00
	2.5	2.5	3.5	3.5	–	2.10	2.10	2.90	2.90	–	3.20	10.00	11.00
	2.5	2.5	3.5	5.0	–	1.86	1.86	2.57	3.71	–	3.20	10.00	11.00
	2.5	3.5	3.5	3.5	–	1.94	2.69	2.69	2.69	–	3.20	10.00	11.00
1:5	2.5	3.5	3.5	5.0	–	1.73	2.40	2.40	3.47	–	3.20	10.00	11.00
	3.5	3.5	3.5	3.5	–	2.50	2.50	2.50	2.50	–	3.20	10.00	11.00
	2.5	2.5	2.5	2.5	2.5	2.00	2.00	2.00	2.00	2.00	3.20	10.00	11.00
	2.5	2.5	2.5	2.5	3.5	1.86	1.86	1.86	1.86	2.57	3.20	10.00	11.00
1:5	2.5	2.5	2.5	2.5	5.0	1.67	1.67	1.67	1.67	3.33	3.20	10.00	11.00
	2.5	2.5	2.5	3.5	3.5	1.73	1.73	1.73	2.40	2.40	3.20	10.00	11.00

	Pobór mocy (kW)			Całkowite natężenie prądu (A)@230V			EER (W/W)	Klasa energetyczna	SEER (W/W)	Klasa energetyczna
	Dane min.	Dane znam.	Dane max.	Dane min.	Dane znam.	Dane max.	Wyd. znam.			
0.55	0.98	1.34	2.44	4.35	5.93	—	—	—	—	
0.55	1.35	1.50	2.44	5.99	6.65	—	—	—	—	
0.55	1.86	1.90	2.44	8.25	8.43	—	—	—	—	
0.55	2.25	3.00	2.44	9.98	13.31	—	—	—	—	
0.55	1.90	3.60	2.44	8.43	15.97	2.74	D	6.20	A++	
0.55	2.24	3.60	2.44	9.94	15.97	2.77	D	6.20	A++	
0.55	2.79	3.60	2.44	12.38	15.97	2.80	D	6.20	A++	
0.55	3.17	3.60	2.44	14.06	15.97	2.87	C	6.20	A++	
0.55	2.58	3.60	2.44	11.45	15.97	2.79	D	6.20	A++	
0.55	3.10	3.60	2.44	13.75	15.97	2.84	C	6.20	A++	
0.55	3.48	3.60	2.44	15.44	15.97	2.87	C	6.20	A++	
0.55	3.50	3.60	2.44	15.53	15.97	2.86	C	6.20	A++	
0.55	3.50	3.60	2.44	15.53	15.97	2.57	E	6.20	A++	
0.55	3.45	3.60	2.44	15.31	15.97	2.90	C	6.20	A++	
0.55	2.78	3.80	2.44	12.33	16.86	2.81	C	6.72	A++	
0.55	3.14	3.80	2.44	13.93	16.86	2.80	C	6.72	A++	
0.55	3.50	4.10	2.44	15.53	18.19	2.86	C	6.74	A++	
0.55	3.50	4.10	2.44	15.53	18.19	2.86	C	6.70	A++	
0.55	3.45	3.80	2.44	15.31	16.86	2.84	C	6.73	A++	
0.55	3.50	4.10	2.44	15.53	18.19	2.86	C	6.70	A++	
0.55	3.50	4.10	2.44	15.53	18.19	2.86	C	6.70	A++	
0.55	3.50	4.10	2.44	15.53	18.19	2.86	C	6.75	A++	
0.55	3.45	4.10	2.44	15.31	18.19	2.90	C	6.70	A++	
0.55	3.45	4.10	2.44	15.31	18.19	2.90	C	6.75	A++	
0.55	3.36	4.10	2.44	14.91	18.19	2.98	C	6.90	A++	
0.55	3.36	4.10	2.44	14.91	18.19	2.98	C	6.90	A++	
0.55	3.36	4.10	2.44	14.91	18.19	2.98	C	6.90	A++	
0.55	3.36	4.10	2.44	14.91	18.19	2.98	C	6.90	A++	
0.55	3.36	4.10	2.44	14.91	18.19	2.98	C	6.90	A++	
0.55	3.33	4.10	2.44	14.77	18.19	3.00	B	7.00	A++	
0.55	3.33	4.10	2.44	14.77	18.19	3.00	B	7.00	A++	
0.55	3.33	4.10	2.44	14.77	18.19	3.00	B	7.00	A++	
0.55	3.33	4.10	2.44	14.77	18.19	3.00	B	7.00	A++	
0.55	3.33	4.10	2.44	14.77	18.19	3.00	B	7.00	A++	
0.55	3.33	4.10	2.44	14.77	18.19	3.00	B	7.00	A++	
0.55	3.33	4.10	2.44	14.77	18.19	3.00	B	7.00	A++	
0.55	3.33	4.10	2.44	14.77	18.19	3.00	B	7.00	A++	
0.55	3.33	4.10	2.44	14.77	18.19	3.00	B	7.00	A++	

MULTI SPLIT Combinations

M5T100-D1

HEATING													
Comb.	Combinations					Rated capacity (kW)					Total heating capacity (kW)		
	Unit A	Unit B	Unit C	Unit D	Unit E	Unit A	Unit B	Unit C	Unit D	Unit E	Min data	Rated data	Max data
1:1	2.5	—	—	—	—	3.60	—	—	—	—	0.80	3.60	6.00
	3.5	—	—	—	—	4.50	—	—	—	—	1.00	4.50	6.00
	5.0	—	—	—	—	6.00	—	—	—	—	1.50	6.00	8.00
	7.0	—	—	—	—	7.00	—	—	—	—	1.50	7.00	8.60
1:2	2.5	2.5	—	—	—	3.60	3.60	—	—	—	3.40	7.20	10.50
	2.5	3.5	—	—	—	3.60	4.50	—	—	—	3.80	8.10	10.50
	2.5	5.0	—	—	—	3.60	6.00	—	—	—	4.40	9.60	10.50
	2.5	7.0	—	—	—	3.57	6.93	—	—	—	4.40	10.50	11.00
	3.5	3.5	—	—	—	4.50	4.50	—	—	—	4.00	9.00	10.50
	3.5	5.0	—	—	—	4.50	6.00	—	—	—	4.40	10.50	11.50
	3.5	7.0	—	—	—	4.11	6.39	—	—	—	4.40	10.50	11.50
	5.0	5.0	—	—	—	5.25	5.25	—	—	—	4.40	10.50	11.50
5.0	7.0	—	—	—	4.85	5.65	—	—	—	4.40	9.50	11.50	
7.0	7.0	—	—	—	5.25	5.25	—	—	—	4.40	10.50	11.50	
1:3	2.5	2.5	2.5	—	—	3.50	3.50	3.50	—	—	4.40	10.50	11.50
	2.5	2.5	3.5	—	—	3.23	3.23	4.04	—	—	4.40	10.50	11.50
	2.5	2.5	5.0	—	—	2.86	2.86	4.77	—	—	4.40	10.50	11.50
	2.5	2.5	7.0	—	—	2.66	2.66	5.18	—	—	4.40	10.50	11.50
	2.5	3.5	3.5	—	—	3.00	3.75	3.75	—	—	4.40	10.50	11.50
	2.5	3.5	5.0	—	—	2.68	3.35	4.47	—	—	4.40	10.50	11.50
	2.5	3.5	7.0	—	—	2.50	3.13	4.87	—	—	4.40	10.50	11.50
	2.5	5.0	5.0	—	—	2.42	4.04	4.04	—	—	4.40	10.50	11.50
	3.5	3.5	3.5	—	—	3.50	3.50	3.50	—	—	4.40	10.50	11.50
	3.5	3.5	5.0	—	—	3.15	3.15	4.20	—	—	4.40	10.50	11.50
	3.5	5.0	5.0	—	—	2.86	3.82	3.82	—	—	4.40	10.50	11.50
	1:4	2.5	2.5	2.5	2.5	—	2.63	2.63	2.63	2.63	—	4.40	10.50
2.5		2.5	2.5	3.5	—	2.47	2.47	2.47	3.09	—	4.40	10.50	11.50
2.5		2.5	2.5	5.0	—	2.25	2.25	2.25	3.75	—	4.40	10.50	11.50
2.5		2.5	2.5	7.0	—	2.12	2.12	2.12	4.13	—	4.40	10.50	11.50
2.5		2.5	3.5	3.5	—	2.33	2.33	2.92	2.92	—	4.40	10.50	11.50
2.5		2.5	3.5	5.0	—	2.14	2.14	2.67	3.56	—	4.40	10.50	11.50
2.5		3.5	3.5	3.5	—	2.21	2.76	2.76	2.76	—	4.40	10.50	11.50
2.5		3.5	3.5	5.0	—	2.03	2.54	2.54	3.39	—	4.40	10.50	11.50
3.5	3.5	3.5	3.5	—	2.63	2.63	2.63	2.63	—	4.40	10.50	11.50	
1:5	2.5	2.5	2.5	2.5	2.5	2.10	2.10	2.10	2.10	2.10	4.40	10.50	11.50
	2.5	2.5	2.5	2.5	3.5	2.00	2.00	2.00	2.00	2.50	4.40	10.50	11.50
	2.5	2.5	2.5	2.5	5.0	1.85	1.85	1.85	1.85	3.09	4.40	10.50	11.50
	2.5	2.5	2.5	3.5	3.5	1.91	1.91	1.91	2.39	2.39	4.40	10.50	11.50

HEAT PUMPS



Ecology

Heiko heat pumps extract energy from the air and use it to heat or cool the building. The R32 refrigerant used is safe for the environment and has a low greenhouse effect.

Compactness

The design of heat pumps is a ready-to-use solution. It does not require the purchase of additional components for the system and does not require additional space to install a separate tank. The module allows easy and safe hydraulic connections

Modern process

The device systems are based on the use of the latest technologies. This allows the pump to work automatically adapts to current weather conditions.

Easy control

Thermal and Thermal Plus heat pumps have a control panel that allows you to quickly and easily change operating parameters. In addition, they are equipped with a Wi-Fi module, which significantly increases the comfort of use.

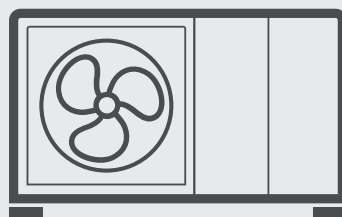

HEAT PUMPS

Models available

Device type

Refrigerant

THERMAL Plus CO + CWU

Monoblock with a hydraulic module
and in-built 250 liters tank



THERMAL CO + CWU

Monoblock with a hydraulic module



Device type

Refrigerant

POOL

Swimming pool pump



6,0 kW

9,0 kW

12,0 kW

15,0 kW

19,0 kW



THERMAL Plus 6



THERMAL Plus 9



THERMAL Plus 12



THERMAL Plus 15



THERMAL Plus 19



THERMAL 6



THERMAL 9



THERMAL 12



THERMAL 15



THERMAL 19

5,0 kW

7,0 kW

9,0 kW

11,0 kW

15,0 kW



Pool 5



Pool 7



Pool 9



Pool 11



Pool 15

HEAT PUMPS

THERMAL Plus CO + CWU

Monoblock with a hydraulic module and integrated DHW storage tank

THERMAL Plus monoblock heat pumps are energy efficient devices which draw energy from the air and use it to heat or cool the building and prepare heat utility water. They can be used in single-family houses. Heiko's heat pumps are advanced devices, which guarantee efficient and safe operation.



Hydraulic module – MONOBLOCK ALL IN ONE

The compact design of the hydraulic module with the integrated 250-litre DHW storage tank is ready to use out of the box. No additional system components need to be purchased, and no extra installation space is required for the DHW tank. The module enables easy and safe hydraulic connections.

**HYDRAULIC
MODULE**
MONOBLOK
ALL IN ONE



Two heating circuits

A THERMAL Plus heat pump can be configured to supply different heat loads at the same time, like a radiator space heating system and an underfloor heating system. The two heating circuits ensure separate management of the temperature in different heat loads; in practical terms, different temperature settings can be made for the radiators and the underfloor heating.



Wide temperature range – reliable operation in all conditions

The Heiko heat pumps are reliable units which operate from -25°C outdoors and can heat DHW to 55°C.

**OPERATING
RANGE**
COOLING
0-50°C



Wi-Fi control

The Wi-Fi control is available in standard, which makes operating the Heiko heat pumps more comfortable. The device can be easily controlled with a dedicated app. Thanks to the Wi-Fi control, Heiko service centre can remotely help the user.



Modern control panel

The integrated control panel enables easy and quick changing of operating parameters. The controller menu is available in several language versions.

**OPERATING
RANGE**
HEATING
-25 - 45°C



Quiet operation

The Heiko THERMAL Plus heat pumps have DC motor fans, a well sound-insulated refrigerant compressor, and an optimised air fan design to ensure very quiet operation already at 52 dB(A). The units can also run in a quiet mode for improved comfort at work or while resting.



Automatic weather control

The Heiko THERMAL Plus heat pumps operate in an automatic process controlled by weather temperature curves. In practice, this means that the heat pump operation is adapted automatically to actual weather conditions without any human intervention.



Frequency converter technology

The frequency converter technology ensures economical operation of the heat pump without sudden voltage spikes in the compressor frequency. As a result, the pump's operation is energy efficient and quiet. The appliances have A+++ energy rating.





Indoor unit



Outdoor unit

Model			HEIKO THERMAL PLUS 6	HEIKO THERMAL PLUS 9	HEIKO THERMAL PLUS 12	HEIKO THERMAL Plus 15	HEIKO THERMAL Plus 19
Seasonal energy efficiency rating, space heating, temperate climate	LWT =35°C		A+++	A+++	A+++	A+++	A+++
	LWT =55°C		A++	A++	A++	A++	A++
Rated heat capacity, including all auxiliary heating units, temperate climate (-10°C)**	LWT =35°C	kW	4	6	8	12	16
	LWT =55°C		4	6	7	11	15
Seasonal energy efficiency, space heating, temperate climate	LWT =35°C	%	186,7	186	185,5	196,8	190,5
	LWT =55°C		133,2	130,4	129,3	130,2	130,11
Annual energy consumption, temperate climate	LWT =35°C	kWh	1827	2826	3225	4829	6953
	LWT =55°C		2809	3728	3997	7602	7750
Indoor sound power level		dB(A)	44	44	44	44	44
Outdoor sound power level		dB(A)	52	53	52	59	61
Special precautions	See the Installation and Service Manuals before attempting the installation.						
Electrical power efficiency	N/A						
Rated heat capacity, including all auxiliary heating units, cold climate	LWT =35°C	kW	3	5	7	10,8	15,1
	LWT =55°C		3	5	6	10,6	14,3
Rated heat capacity, including all auxiliary heating units, warm climate	LWT =35°C	kW	6	8	10	13,8	18,2
	LWT =55°C		6	7	8	13,1	16,1
Seasonal energy efficiency, space heating, cold climate	LWT =35°C	%	155	153	156	160	156
	LWT =55°C		117	105	110	115	110
Seasonal energy efficiency, space heating, warm climate	LWT =35°C	%	189	192	194	196	194
	LWT =55°C		147	143	142	143	140
Annual energy consumption with regard to final energy amount – cold climate	LWT =35°C	kWh	2071	3149	4020	7020	8825
	LWT =55°C		3089	4100	4112	7910	9930
Annual energy consumption with regard to final energy amount – warm climate	LWT =35°C	kWh	1710	3094	3480	6243	8105
	LWT =55°C		2550	3510	3560	6913	8590
Heat pump unit power supply		V/Ph/Hz	220-240/1/50	220-240/1/50	220-240/1/50	380- 420 /3/50	380 - 420 /3/50
Electrical heater power supply		V	230	400	400	400	400
Heating (LWT = 35°C) (Outdoor temperature 2°C, 85% RH, EWT 30°C, LWT 35°C)	Capacity	kw	6,1	7,8	10,1	13,8	18,5
	COP	-	3,8	3,87	3,9	4	4,47
Heating (LWT = 35°C) (Outdoor temperature 7°C, 85% RH, EWT 47°C, LWT 55°C)	Capacity	kw	6,5	9,2	11,6	15,5	18,5
	COP	-	4,61	4,38	4,3	5	4,47
Cooling (LWT = 18°C) (Outdoor temperature 35°C, EWT 23°C, LWT 18°C)	Capacity	kw	7,45	9,5	9,8	18,6	22,5
	EER	-	4,05	4,23	3,9	4	7,35
Cooling (LWT = 7°C) Outdoor temperature 35°C, EWT 12°C, LWT 7°C)	Capacity	kw	7,45	9,5	9,8	13,1	15,8
	EER	-	4,05	4,23	3,9	3	2,94
Current protection control		B	25 (3F)	25 (3F)	25 (3F)	25 (3F)	25 (3F)
Power supply (number of conductors x cross section)		mm ²	5 x 2,5	5 x 2,5	5 x 4	5 x 4	5 x 4
Current protection control		B	from indoor unit			25 (3F)	25 (3F)
Power supply (number of conductors x cross section)		mm ²	3 x 2,5	3 x 2,5	3 x 2,5	5 x 4	5 x 4
Dimensions of the indoor unit (W x H x D)	Net/gross	mm	600x680x1780/ 650x750x1960	600x680x1780/ 650x750x1960	600x680x1780/ 650x750x1960	600x680x1780/ 650x750x1960	600x680x1780/ 650x750x1960
		mm	1010x370x700/ 1040x455x730	1165x370x845/ 1210x455x875	1165x370x845/ 1210x455x875	1085x390x1400/ 1100x400x1450	1085x390x1400/ 1100x400x1450
Indoor unit weight		kg	125 / 135	125 / 135	125 / 135	125 / 135	125 / 135
Outdoor unit weight		kg	67 / 78	80 / 95	85 / 105	125 / 135	125 / 135
Compressor	Type		Twin Rotary – 1				
Sensors			TC (system temp.), TW (DHW temp.), TV1 (1st circuit temp.),TV2 (2nd circuit temp.), TR (room temp.)				
Integrated electrical heater		kW	3	6	6	6	6
Refrigerant	Type / amount of gas	kg	R32 / 0,9	R32 / 1,4	R32 / 1,8	R32 / 2,55	R32 / 2,6
	Cooling	°C	0 ~50	0 ~50	0 ~50	0 ~50	0 ~50
Recommended operating range	Heating	°C	-25 - 45	-25 - 45	-25 - 45	-25 - 45	-25 - 45
	DHW	°C	-25 - 55	-25 - 55	-25 - 55	-25 - 55	-25 - 55
Water side heat exchanger	Type		Plate heat exchanger				
Water-side connection	Type	cal	1	1	1	G1 - 1/4	G1 - 1/4
Water Pump	Max lifting height	m	7,5	7,5	7,5	7,5	7,5
	Cooling	°C	7 - 25	7 - 25	7 - 25	7 - 25	7 - 25
Outlet water temperature range	Heating	°C	20 - 55	20 - 55	20 - 55	20 - 55	20 - 55
	DHW (tank)	°C	25 - 55	25 - 55	25 - 55	25 - 55	25 - 55

* When installed and started by the Authorised Service.

** Heating power for outdoor temperature of -10°C

HEAT PUMPS

THERMAL CH + DHW

Monoblock with hydraulic module

THERMAL monoblock heat pumps are energy efficient devices which draw energy from the air and use it to heat or cool the building and prepare heat utility water. They can be used in single-family houses. Heiko's heat pumps are advanced devices, which guarantee efficient and safe operation.



Two heating circuits

A standard THERMAL heat pump can be configured to supply different heat loads at the same time, like a radiator space heating system and an underfloor heating system. With two heating circuits, the temperature in different heat sources can be managed separately; in practical terms, different temperature settings can be made for the radiators and the underfloor heating.



Wide temperature range – reliable operation in all conditions

The Heiko heat pumps are reliable units which operate from -25°C outdoors and can heat DHW to 55°C.



Wi-Fi control

The Wi-Fi control is available in standard, which makes operating the Heiko heat pumps more comfortable. The device can be easily controlled with a dedicated app. Thanks to the Wi-Fi control, Heiko service centre can remotely help the user.



Modern control panel

The integrated control panel enables easy and quick changing of operating parameters. The controller menu is available in several language versions.



Quiet operation

The Heiko THERMAL heat pumps have DC motor fans, a well sound-insulated refrigerant compressor, and an optimised air fan design to ensure very quiet operation already at 52 dB(A). The units can also run in a quiet mode for improved comfort at work or while resting.



Automatic weather control

The Heiko THERMAL heat pumps operate in an automatic process controlled by weather temperature curves. In practice, this means that the heat pump operation is adapted automatically to actual weather conditions without any human intervention.



Frequency converter technology

The frequency converter technology ensures economical operation of the heat pump without sudden voltage spikes in the compressor frequency. As a result, the pump's operation is energy efficient and quiet. The appliances have A+++ energy rating.

AUTOMATIC

WEATHER
CONTROL

OPERATING RANGE

COOLING
0-50°C

OPERATING RANGE

HEATING
-25 - 45°C





Indoor unit



Outdoor unit

Model			HEIKO THERMAL 6	HEIKO THERMAL 9	HEIKO THERMAL 12	HEIKO THERMAL 15	HEIKO THERMAL 19
Seasonal energy efficiency rating, space heating, temperate climate	LWT = 35°C		A+++	A+++	A+++	A+++	A+++
	LWT = 55°C		A++	A++	A++	A++	A++
Rated heat capacity, including all auxiliary heating units, temperate climate (-10°C)**	LWT = 35°C	kW	4	6	8	12	16
	LWT = 55°C		4	6	7	11	15
Seasonal energy efficiency, space heating, temperate climate	LWT = 35°C	%	186,7	186	185,5	196,8	190,5
	LWT = 55°C		133,2	130,4	129,3	130,2	130,11
Annual energy consumption, temperate climate	LWT = 35°C	kWh	1827	2826	3225	4829	6953
	LWT = 55°C		2809	3728	3997	7602	7750
Indoor sound power level		dB(A)	44	44	44	44	44
Outdoor sound power level		dB(A)	52	53	52	59	61
Special precautions	Przed montażem prosimy zapoznać się z instrukcją montażową oraz serwisową						
Electrical power efficiency	Nie dotyczy						
Rated heat capacity, including all auxiliary heating units, cold climate	LWT = 35°C	kW	3	5	7	10,8	15,1
	LWT = 55°C		3	5	6	10,6	14,3
Rated heat capacity, including all auxiliary heating units, warm climate	LWT = 35°C	kW	6	8	10	13,8	18,2
	LWT = 55°C		6	7	8	13,1	16,1
Seasonal energy efficiency, space heating, cold climate	LWT = 35°C	%	155	153	156	160	156
	LWT = 55°C		117	105	110	115	110
Seasonal energy efficiency, space heating, warm climate	LWT = 35°C	%	189	192	194	196	194
	LWT = 55°C		147	143	142	143	140
Annual energy consumption with regard to final energy amount - cold climate	LWT = 35°C	kWh	2071	3149	4020	7020	8825
	LWT = 55°C		3089	4100	4112	7910	9930
Annual energy consumption with regard to final energy amount - warm climate	LWT = 35°C	kWh	1710	3094	3480	6243	8105
	LWT = 55°C		2550	3510	3560	6913	8590
Heat pump unit power supply		V/Ph/Hz	220-240/1/50	220-240/1/50	220-240/1/50	380-420 / 3 / 50	380-420 / 3 / 50
Electrical heater power supply		V	230	400	400	400	400
Current protection for the electric heater		B	16	16 (3F)	16 (3F)	16 (3F)	16 (3F)
Heater supply (number of conductors x cross section)		mm ²	3 x 2,5	5 x 2,5	5 x 2,5	5 x 2,5	5 x 2,5
Heating (LWT = 35°C) (Outdoor temperature 2°C, 85% RH, EWT 30°C, LWT 35°C)	Capacity	kw	6,1	7,8	10,1	13,8	18,5
	COP	-	3,8	3,87	3,9	4	4,47
Heating (LWT = 35°C) (Outdoor temperature 7°C, 85% RH, EWT 47°C, LWT 55°C)	Capacity	kw	6,5	9,2	11,6	15,5	18,5
	COP	-	4,61	4,38	4,3	5	4,47
Cooling (LWT = 18°C) (Outdoor temperature 35°C, EWT 23°C, LWT 18°C)	Capacity	kw	7,45	9,5	9,8	18,6	7,35
	EER	-	4,05	4,23	3,9	4	22,5
Cooling (LWT = 7°C) (Outdoor temperature 35°C, EWT 12°C, LWT 7°C)	Capacity	kw	7,45	9,5	9,8	13,1	15,8
	EER	-	4,05	4,23	3,9	3	2,94
Current protection control		B	20	25	25	25	25
Power supply (number of conductors x cross section)		mm ²	3 x 2,5	3 x 3,5	3 x 2,5	3 x 2,5	3 x 2,5
Current protection control		B	20	25	25	25 (3F)	25 (3F)
Power supply (number of conductors x cross section)		mm ²	3 x 2,5	3 x 2,5	3 x 4	5 x 2,5	5 x 4
Dimensions of the indoor unit (W x H x D)	Net/gross	mm	1010x370x700/ 1060x420x750	1165x370x845/ 1200x420x900	1165x370x845/ 1200x420x900	1085x390x1450/ 1185x400x1550	1086x390x1450/ 1185x400x1550
Indoor unit weight		kg	25 / 31	25 / 31	25 / 31	25 / 31	25 / 31
Outdoor unit weight		kg	65 / 76	78 / 90	85 / 94	130 / 140	140 / 150
Compressor	Type	Twin Rotary - 1					
Sensors	TC (temp. układu), TW (temp. CWU), TV1 (temp. pierwszego obiegu), TV2 (temp. drugiego obiegu), TR (temp. pomieszczenia)						
Integrated electrical heater		kW	3	6	6	6	6
Refrigerant	Type / amount of gas	kg	R32 / 0,9	R32 / 1,4	R32 / 1,8	R32 / 2,55	R32 / 2,6
	Cooling	°C	0 - 50	0 - 50	0 - 50	0 ~50	0 ~50
Recommended operating range	Heating	°C	-25 - 45	-25 - 45	-25 - 45	-25 - 45	-25 - 45
	DHW	°C	-25 - 55	-25 - 55	-25 - 55	-25 - 55	-25 - 55
Water side heat exchanger	Type	Płytkowy wymiennik ciepła					
Water-side connection	Type	cal	1	1	1	G1 - 1/4	G1 - 1/4
Water Pump	Max lifting height	m	7,5	7,5	7,5	7,5	7,5
	Cooling	°C	7 - 25	7 - 25	7 - 25	7 - 25	7 - 25
Outlet water temperature range	Heating	°C	20 - 55	20 - 55	20 - 55	20 - 55	20 - 55
	DHW (tank)	°C	25 - 55	25 - 55	25 - 55	25 - 55	25 - 55

* Przy montażu i uruchomieniu przez Autoryzowany Punkt Serwisowy.

** Jest to moc grzewcza dla temperatury zewnętrznej -10°C

HEAT PUMPS

POOL

Swimming pool pump

The Heiko POOL heat pumps are devices that can be connected directly to the process circuit of swimming pool water. They are installed near a swimming pool and they can both heat or cool the water. The heat pumps have a condenser, which is resistant to chlorinated or salt water. They are equipped with a panel for quick and easy control. The Heiko POOL heat pumps are a perfect solution not only for home pools, but also wherever precise control of water temperature is necessary.



R32 refrigerant

The R32 refrigerant used in the heat pumps makes them far more efficient than the appliances operating on the commonly used R410A refrigerant.



Smart controller

The integral smart controller enables quick and easy operation through the panel placed directly on the heat pump.

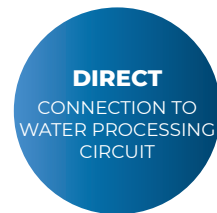

Low power consumption

Innovative solutions enabled a significant reduction of energy consumption.



Heat pump can be controlled by the app

The pool heat pump can be controlled using the SmartLife application, which is available on Android and iOS. This facilitates the operation of the device, thanks to which the User can set any temperature and plan the operation of the device.





Model			HEIKO POOL 5	HEIKO POOL 7	HEIKO POOL 9	HEIKO POOL 11	HEIKO POOL 15
Outdoor sound power level		dB(A)	50	51	52	54	54
Special precautions	See the Installation and Service Manuals before attempting the installation.						
Power supply		V/Ph/Hz	220-240/1/50	220-240/1/50	220-240/1/50	220-240/1/50	220-240/1/50
Air temperature 26°C/Water temperature 26°C	Capacity	kW	7,2	9,5	13,0	14,7	19,8
	COP	-	13,6	14,0	16,4	16,5	16,7
Air temperature 15°C/Water temperature 26°C	Capacity	kW	5,4	6,7	8,7	10,8	14,7
	COP	-	6,5	6,6	7,8	7,7	7,9
Current protection control		A	16	16	16	20	20
Power supply of the electric heaters		mm ²	3 x 2,5	3 x 2,5	3 x 2,5	3 x 4	3 x 4
Dimensions of the outdoor unit (W x H x D)	net/gross		848x375x643/ 888x396x798	848x375x643/ 888x396x798	848x375x643/ 888x396x798	932x375x643/ 968x396x798	1129x395x743/ 1166x416x898
Outdoor unit weight		kg	41,5 / 43	43 / 45	47,5 / 50	54,5 / 57	68 / 72
Compressor	Type	Hermetic Rotary DC Inverter Compressor					
Max pool volume (m ³)*			15~30	22~43	30~56	34~68	45~85
Compressor manufacturer			GMCC	GMCC	GMCC	MITSUBISHI	GMCC
Refrigerant	Type / amount of gas	kg	R32 / 0,45	R32 / 0,45	R32 / 0,6	R32 / 0,65	R32 / 1
Expansion valve			Electronic				
Recommended operating range	Cooling	°C	-7 ~ 43	-7 ~ 43	-7 ~ 43	-7 ~ 43	-7 ~ 43
	Heating	°C	-7 ~ 43	-7 ~ 43	-7 ~ 43	-7 ~ 43	-7 ~ 43
Water side heat exchanger	Type	Titanium heat exchanger					
Water-side connection	Type	mm	PVC 50				
Outlet water temperature range	Cooling	°C	15 ~ 40	15 ~ 40	15 ~ 40	15 ~ 40	15 ~ 40
	Heating	°C	8 ~ 28	8 ~ 28	8 ~ 28	8 ~ 28	8 ~ 28

* Calculated for an in-ground private swimming pool covered with a bubble cover.

HEIKO Dimensions – air conditioners

Wall-mounted units

JS025-A1, JS035-A1



JS025-QW2, JS035-QW2

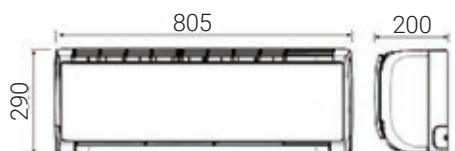

JS050-QW2

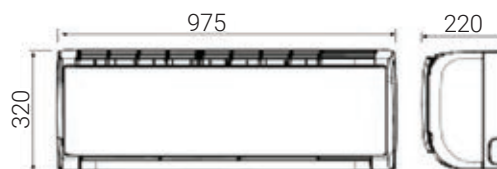

JS035-C1, JS035-D2, JS025-C2, JS035-C2, JS035-D1

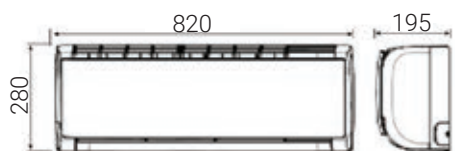

JS050-C2

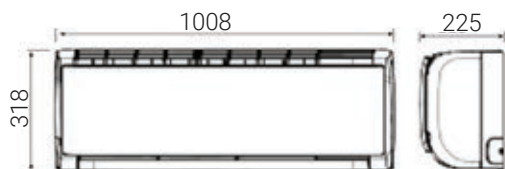

JS070-C2

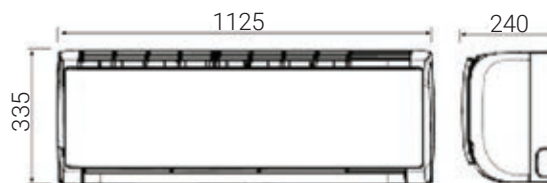

Cassette air conditioners

CA035-A1, CA050-A1

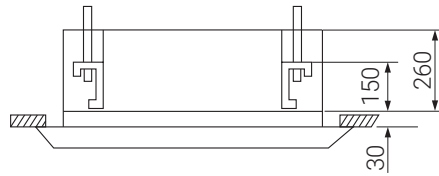
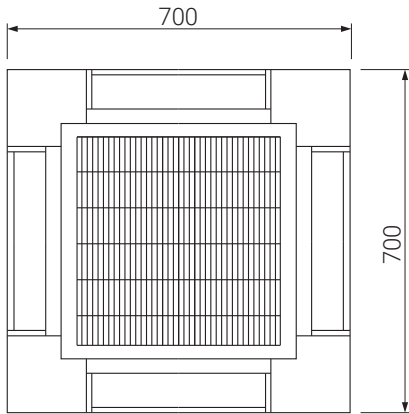

CA070-A1, CA100-A1

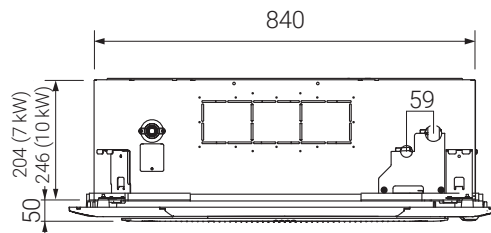
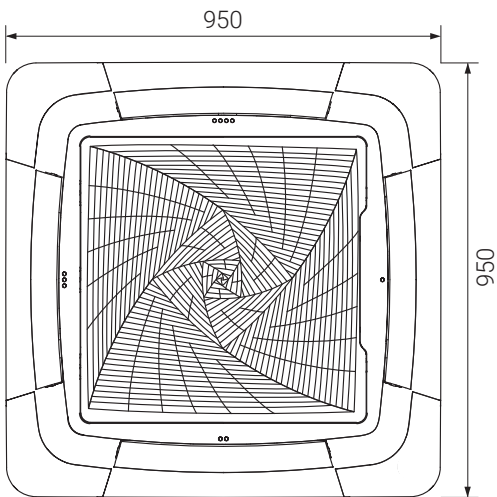

Outdoor units

JZ035-C1, JZ025-C2, JZ035-C2

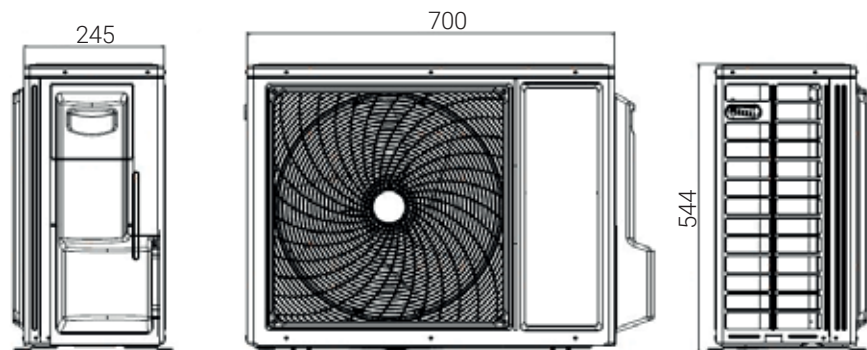

JZ070-C1

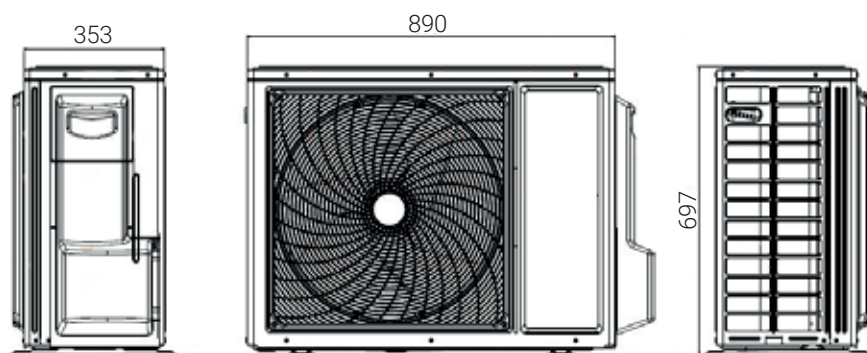

JZ025-A1, JZ035-A1, JZ050-C2, JZ050-Q2

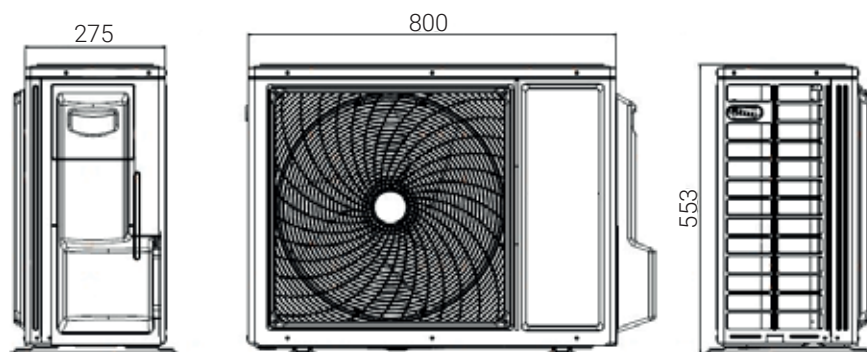

JZ025-Q2, JZ035-Q2

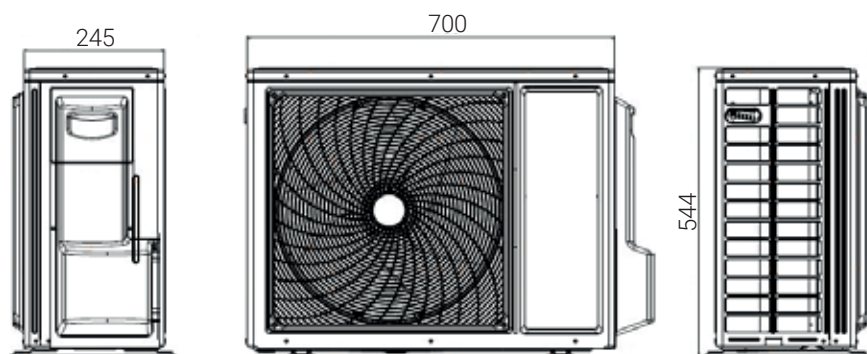

Outdoor units

JZ050-A1

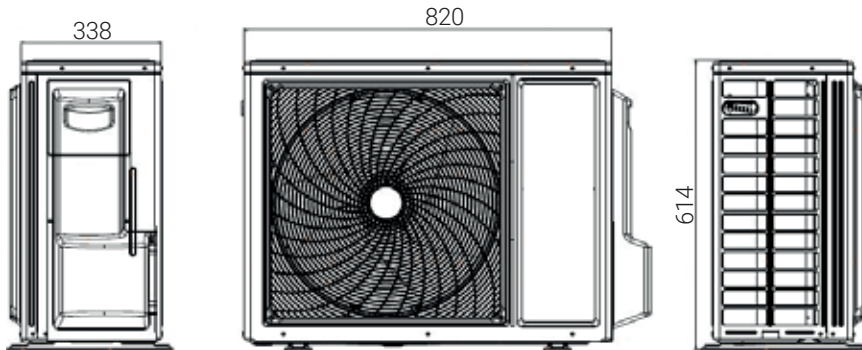

JZ070-A1

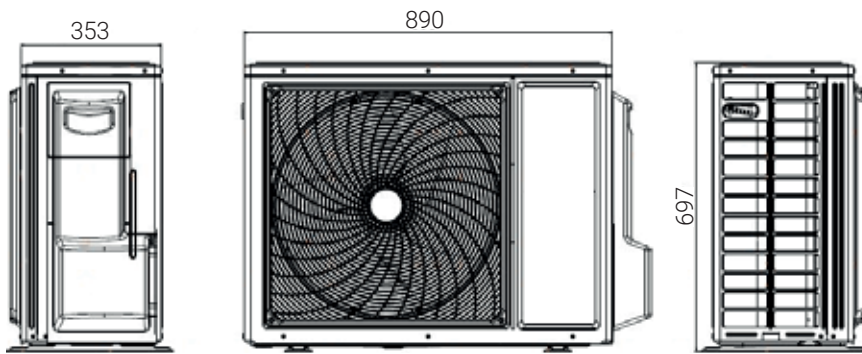

JZ100-A1

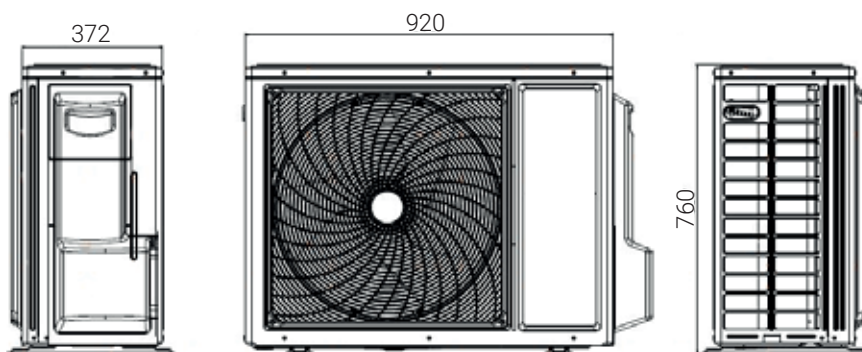

Outdoor units

M2T050-D1

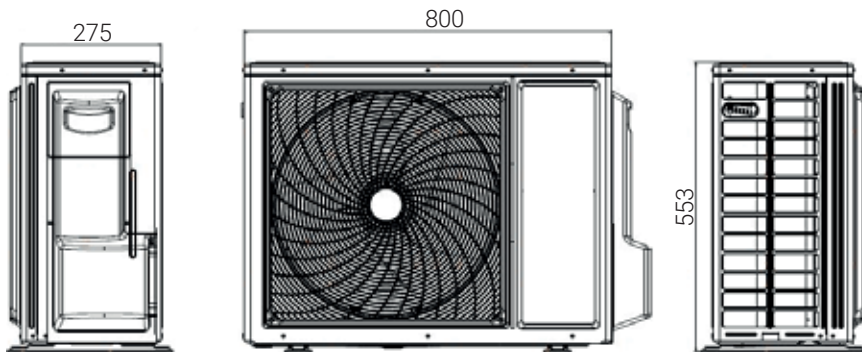

M3T070-D1

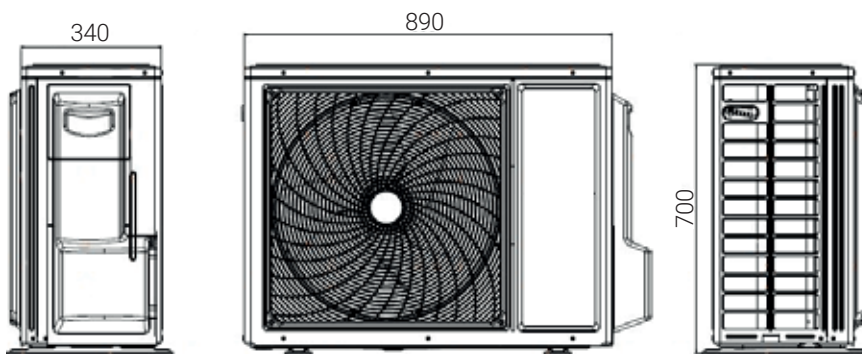

M5T100-D1

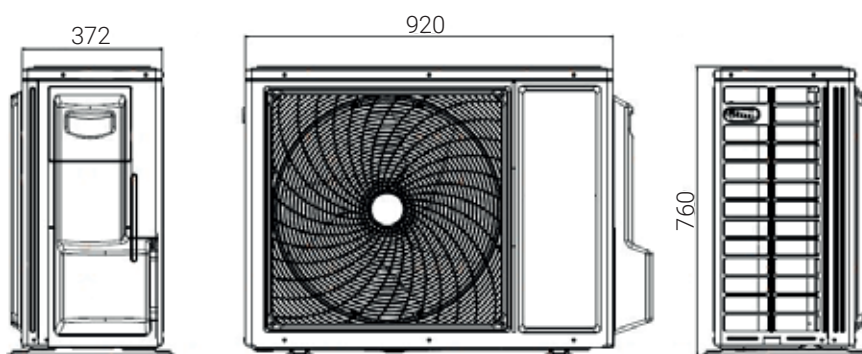

HEIKO Dimensions - heat pumps

Indoor units

THERMAL Plus 6, 9, 12, 15, 19

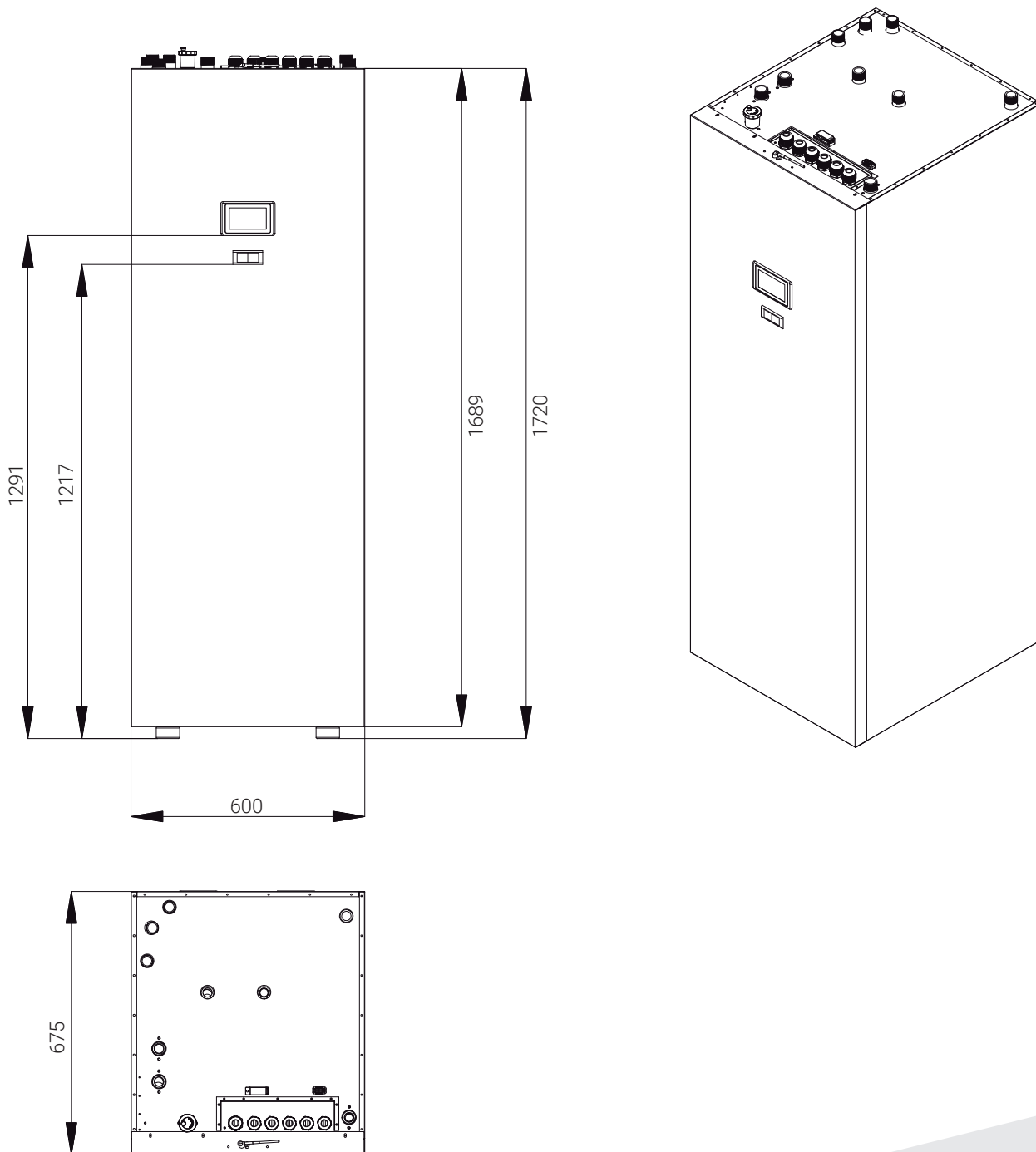

Outdoor units

THERMAL Plus 6

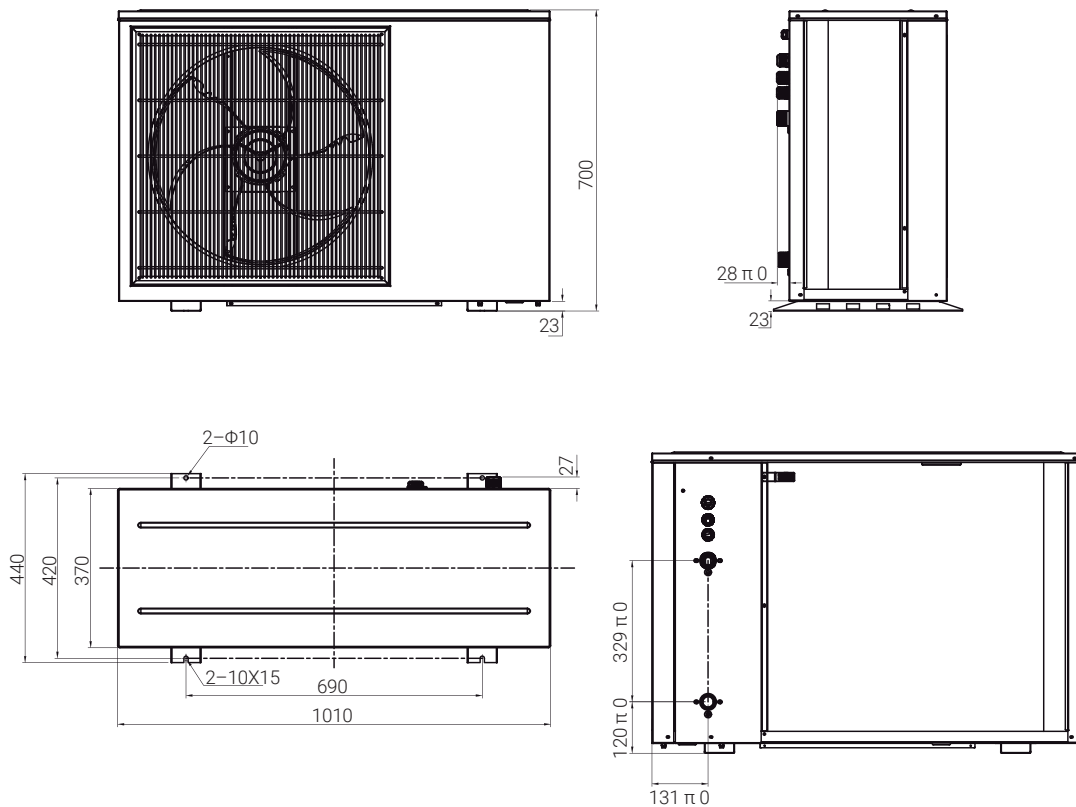

THERMAL Plus 9, 12

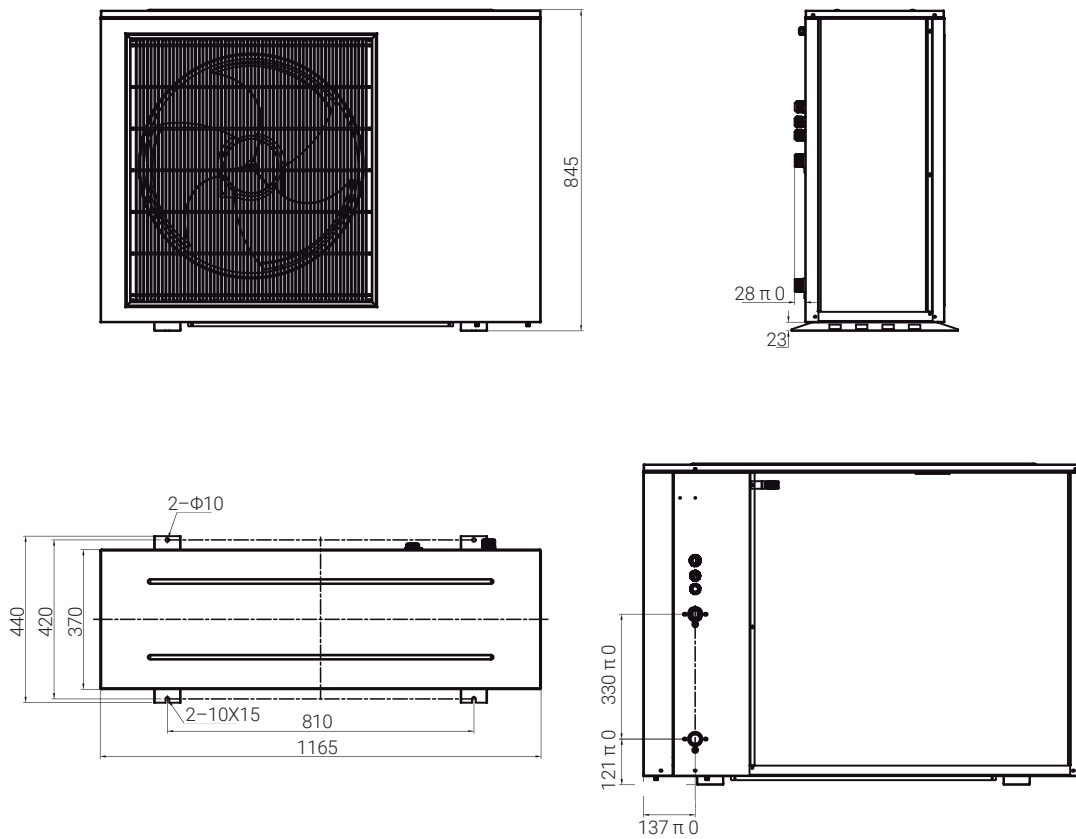

Outdoor units

THERMAL Plus 15, 19

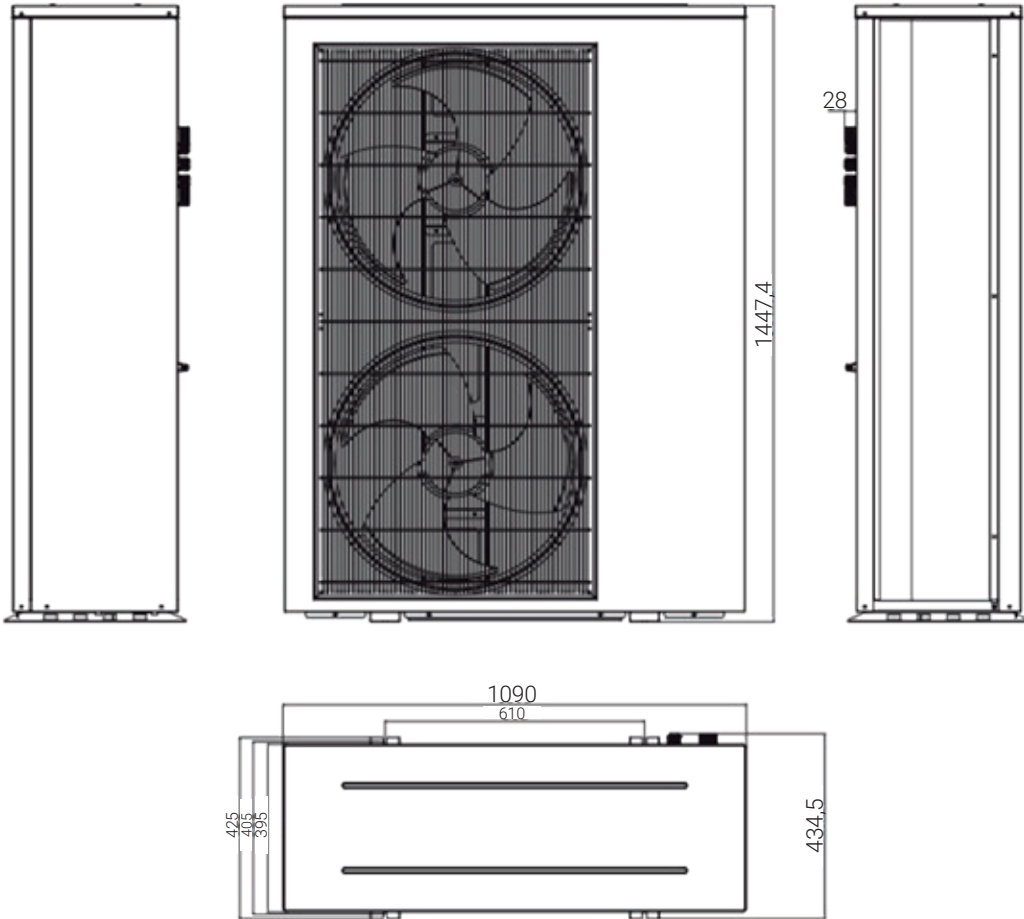

Indoor units

THERMAL 6, 9, 12, 15, 19

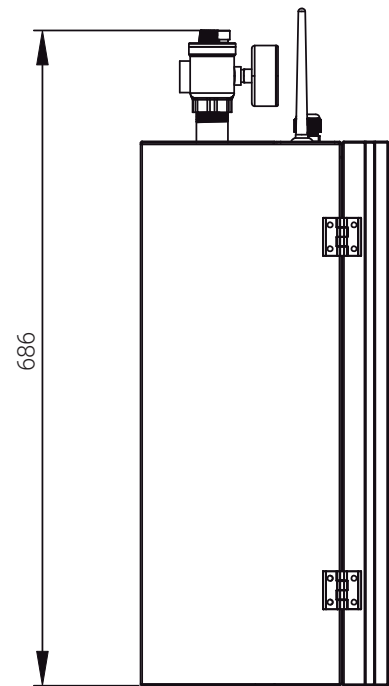
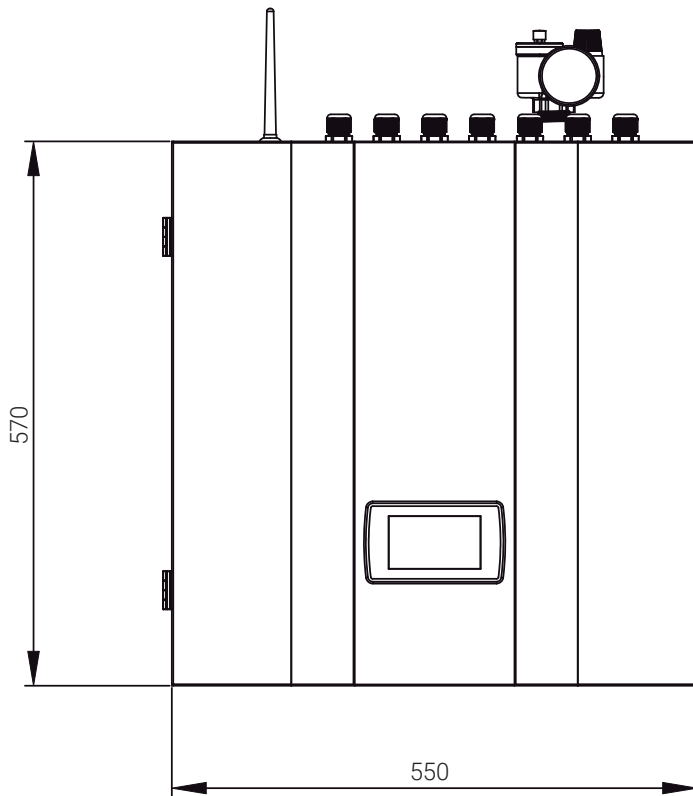
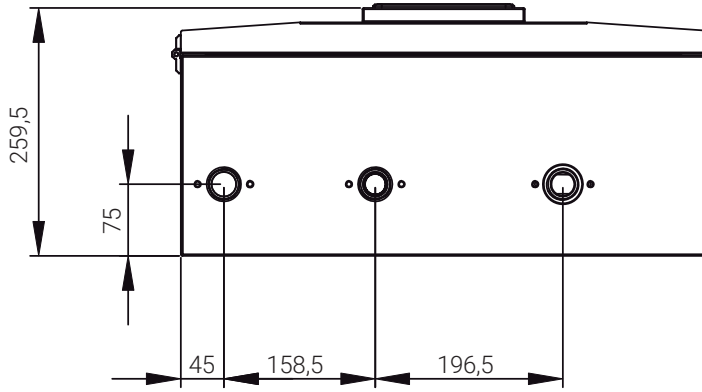

Outdoor units

THERMAL 6

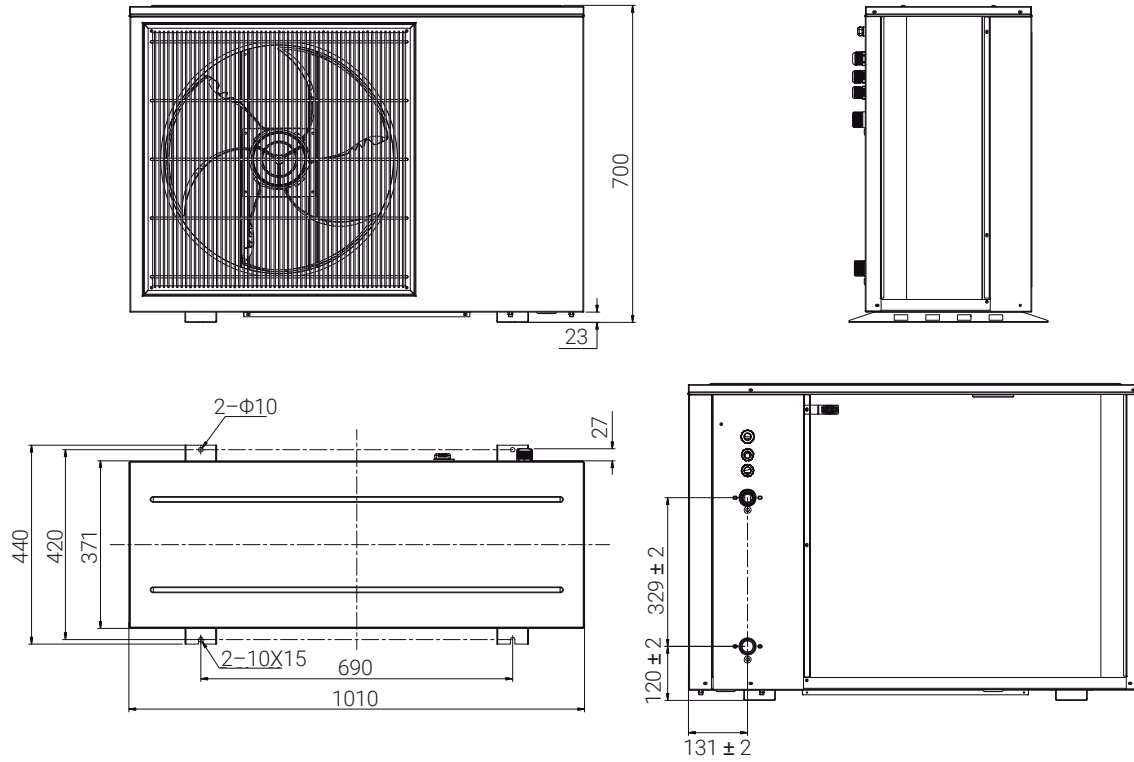

THERMAL 9, 12

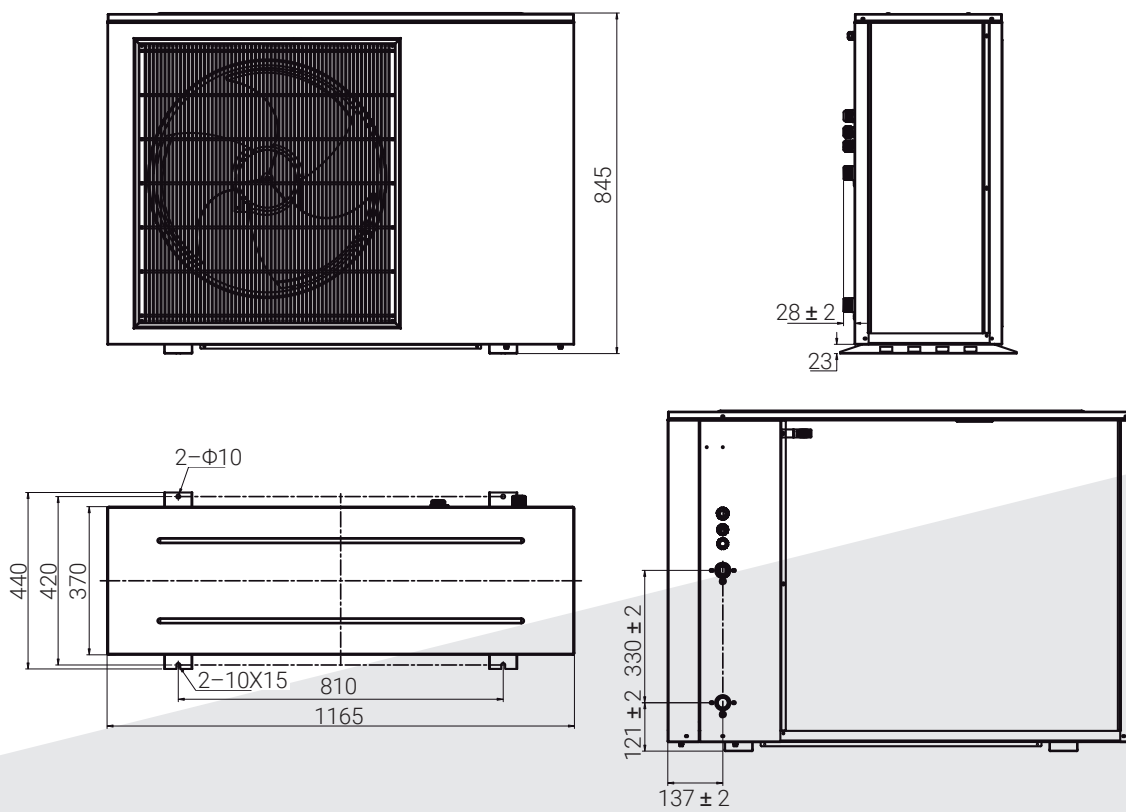

Outdoor units

THERMAL 15, 19

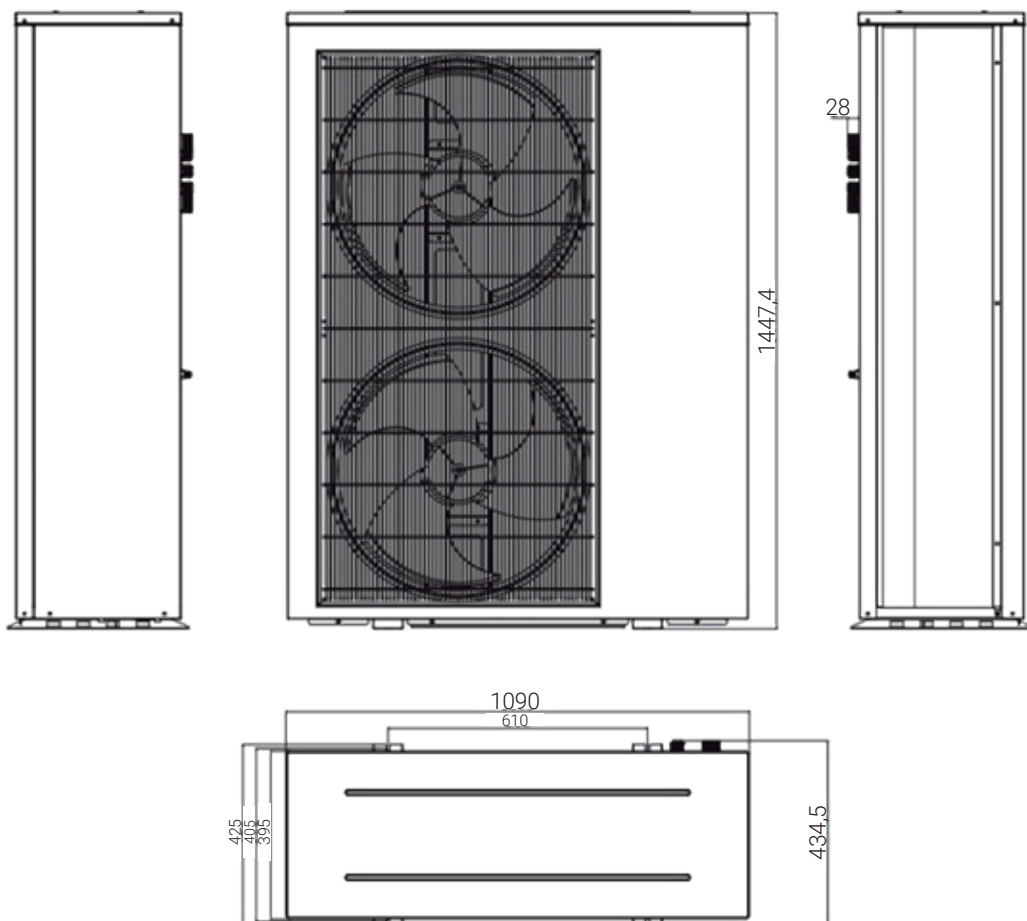

Outdoor units

POOL 5, 7, 9

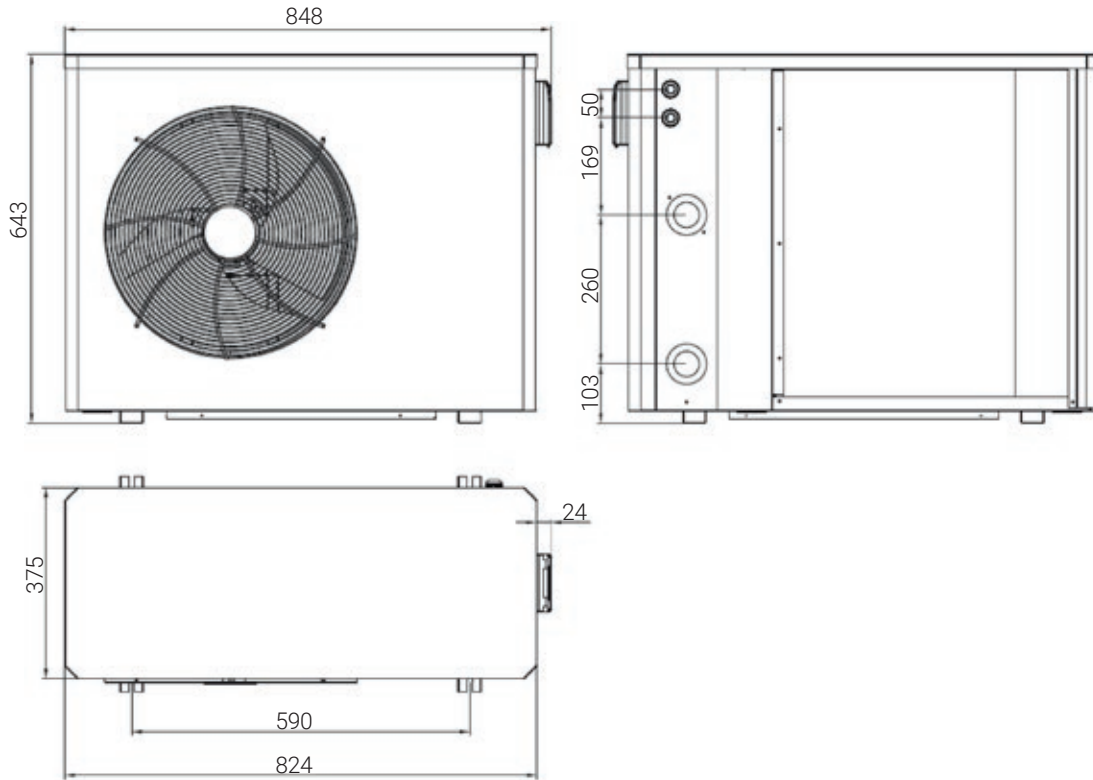

POOL 11

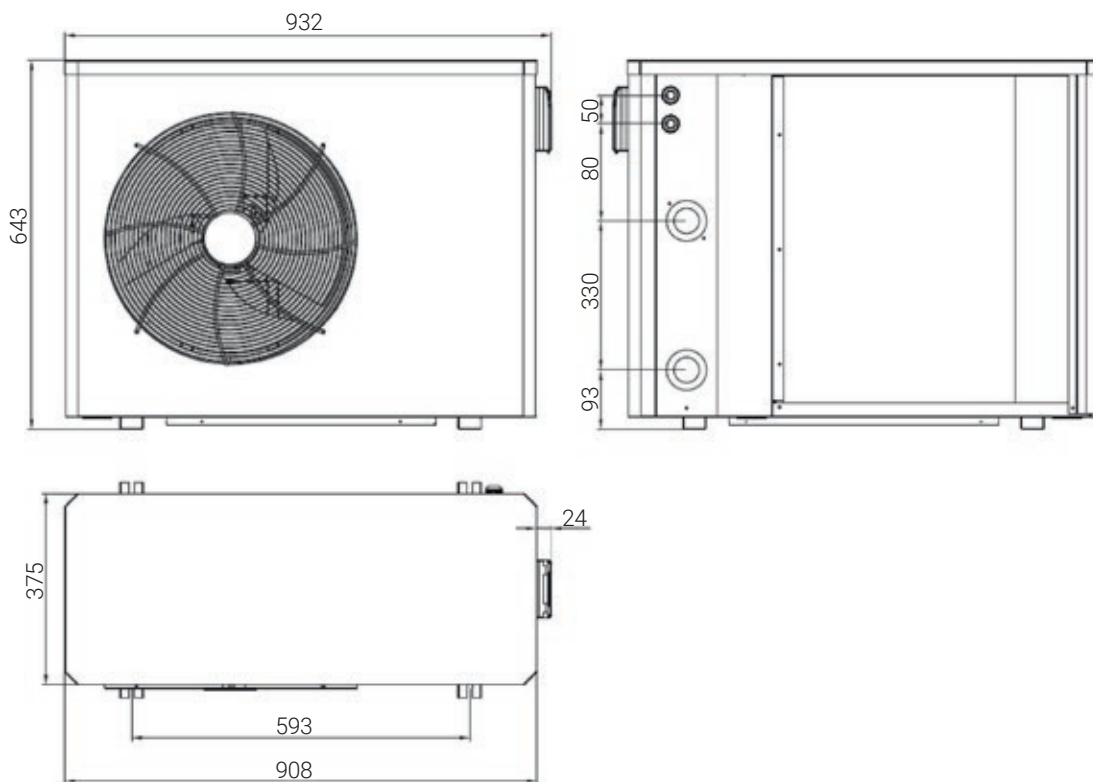

Outdoor units

POOL 15

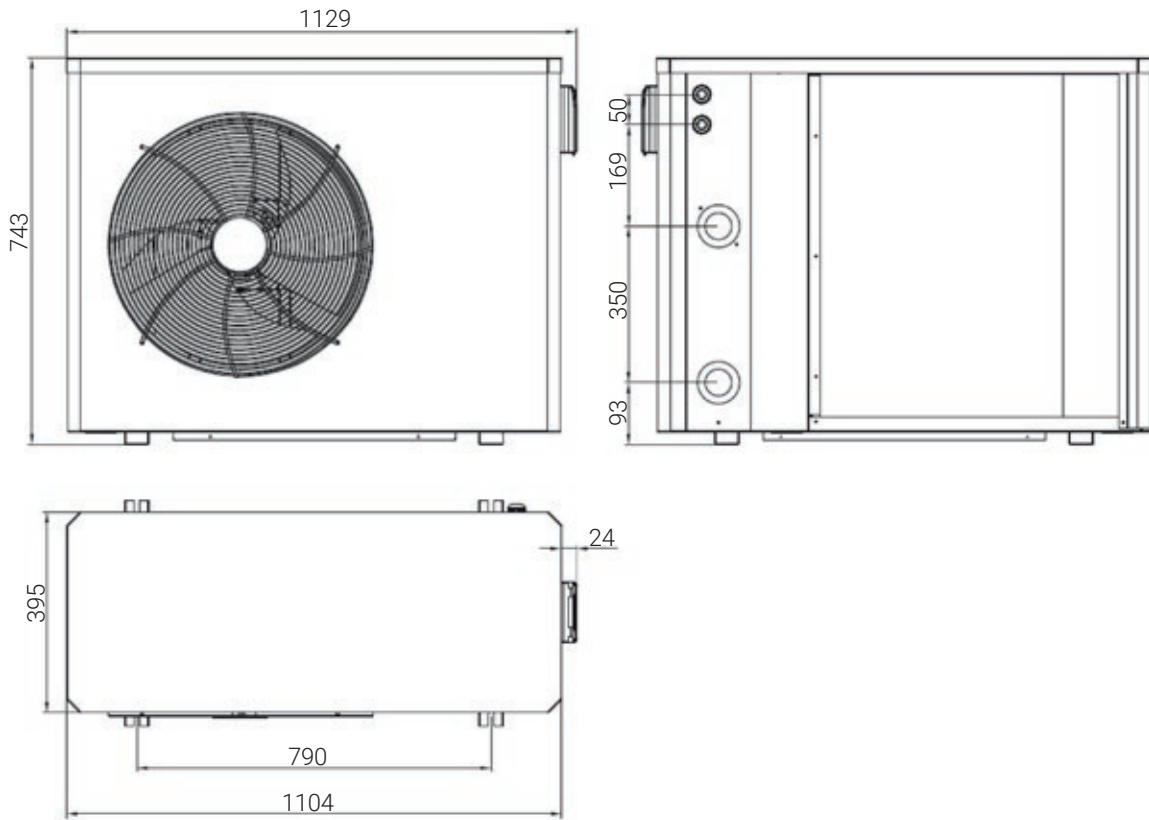



HEIKO

**The General Distributor of HEIKO
air conditioning systems and heat pumps**

REFSYSTEM Sp. z o.o.
ul. Metalowców 5, 86-300 Grudziądz

Tel. +48 723 737 378

www.heiko.pl